

NV9 USB OPERATIONS MANUAL

INTELLIGENCE IN VALIDATION



A.u.S. Spielgeräte GesmbH
Scheydgasse 48 A-1210 Wien
Tel. +43-1-271 66 00 Fax.+43-1-271 66 00 75
E-mail: verkauf@aus.at
<http://www.aus.at>
Öffnungszeiten: Mo-Fr. 9-18 Uhr

CONTENTS

1 Introduction	3
2 Environment And Power Requirements	5
3 General Description	6
4 Machine Interfaces	7
4.1 Bezel LEDs	7
4.2 Hardware	7
4.2.1 Ports And Buttons	7
4.2.2 Interface Connector Pin Details	8
4.2.3 Configuration Button Functions	9
4.3 Protocols	10
4.3.1 eSSP - Encrypted Smiley® Secure Protocol	10
4.3.2 Smiley® Secure Protocol - SSP	11
4.3.3 ccTalk® Protocol - CCT	12
4.3.4 Multi-Drop Bus/Internal Communications Protocol (MDB/ICP)	13
4.3.5 Parallel	15
4.3.6 Pulse	17
4.3.7 Serial Input/Output - SIO	19
4.4 Using NV9 USB Configuration Cards	21
5 Mechanical	22
5.1 Changing Or Removing The Bezels	22
5.2 Cash Box Options	22
6 Routine Maintenance	23
6.1 Cleaning	23
6.2 Belt Cleaning	24
6.3 Debris Clearing	24
6.4 Belt Changing	25
6.5 Re-Calibration	25
7 Diagnostics	26
8 Support	27
Appendix A - How To Order a NV9 USB Validator	29
Appendix B - Dimension Drawing	30
Appendix C - Configuration Cards	31
Appendix D - Escrow Control	33
Appendix E - USB To Validator Cable Assembly - CN392	34
Appendix F - Bezel Options	35
Appendix G - Cash Boxes	37
Index of Tables	38
Index of Figures	38
Revision History	39
Configuration Card	40



1 INTRODUCTION

This manual describes the operation of the NV9 USB Bank Note Validator as fitted with Firmware Version 3.26 or greater.

This document is intended for those who will:

- Install the NV9 USB equipment.
- Maintain the NV9 USB equipment.

Although information is included which will allow a degree of fault diagnosis and repair, it is recommended that for all but simple mechanical repairs, the unit must be returned to an approved service centre for repair.

For more concise information, addressed primarily to maintenance, please refer for the concise manual on our website.

CAUTIONS

- This product must be fitted with a 3 A (ampere) fuse before use.
- The NV9 USB validator is pin for pin compatible with NV7/8/9/10, but not pin for pin compatible with the NV2/3/4/4x or 5 series products.
- Never exceed the recommended environmental and electrical limits.
- Do not attempt to lubricate the mechanisms as this may affect the note transport.
- Do not polish the lens as this may alter the optical characteristics.
- If the NV9 USB validator is disassembled the unit must be re-calibrated and re-initialised, following re-assembly.

WARNING

- Only suitably trained personnel should carry out any work on this equipment in accordance with all current local, national and international health and safety regulations.
- We recommend that you study this manual as there are many new features permitting new uses and more secure applications.
- If you do not understand any part of this manual please contact the factory, contact details are below, for assistance. In this way we may continue to improve our product.
- The NV9 USB Validator has been designed to minimise any performance variation over time. Much of this is achieved by careful Hardware and Software design.
- Innovative Technology Ltd has a policy of continual product improvement. As a result the products supplied may vary from the specification described here.

This manual can be printed in A4 or letter sizes, without losing the scale. This is especially important when printing the configuration card on the final page of this manual.





A.u.S. Spielgeräte GesmbH
Scheydgasse 48 A-1210 Wien
Tel. +43-1-271 66 00 Fax.+43-1-271 66 00 75
E-mail: verkauf@aus.at
<http://www.aus.at>
Öffnungszeiten: Mo-Fr. 9-18 Uhr

2 ENVIRONMENT AND POWER REQUIREMENTS

ENVIRONMENT

Environment	Minimum	Maximum
Temperature	+3°C	+50°C
Humidity	5%	95% Non condensing

Table 1 - Environmental Requirements

POWER REQUIREMENTS

Electrical Supply	Minimum	Maximum
Supply Voltage (V DC) Absolute Limits	+10.8 V	+14.2 V
MDB IF5 Version Supply Voltage	+18V	+48V DC or 34V AC
Supply Ripple Voltage	0 V	0.25 V @ 100 Hz
Supply Currents		
Standby		0.2A
Running		1A
Peak (Motor Stall)		1.5A

Table 2 - Power Requirements

Interface Logic Levels	Logic Low	Logic High
Inputs	0 V to + 0.5 V	+3.7 V + 12 V
Outputs with 2K2Ω pull up	0.6 V	Pull up voltage of host interface
Maximum Current Sink	50mA per output	

Table 3 - Interface Logic Levels

CAUTION

- If the input voltage falls below 10.8 V the NV9 USB may not operate correctly (will reject notes). The front bezel lights will flash to indicate incorrect conditions.
- It is recommended that the power supply used can supply at least 1.5 amperes.



3 GENERAL DESCRIPTION

The NV9 USB Bank Note Validator is a compact unit (see Figure 1), suitable for most money machines. It will accept up to 15 different denominations of notes in the serial control mode.

The NV9 USB is designed for easy installation in most machines. To see the general dimensions of the NV9 USB, refer to Appendix B – Dimension Drawing.



Figure 1 - The NV9 USB Validator

CURRENCY/ FIRMWARE

The currency and firmware files have been combined in the new NV9 USB to simplify the downloading of files. The NV9 USB Validator leaves the factory preset to at least one currency and one firmware interface so that it is ready for immediate installation. If the currency data set needs to change this may be done using the PC based Validator Management Software. If the firmware interface needs to change this may be done using either the PC based Validator Management Software or a configuration card. New currencies and applications are being tested all the time, please refer to our web site or contact the factory for information concerning specific currencies if they are not already included on our approved list.

The NV9 USB has been designed for easy installation in most machines. The “Smiley mouth” allows insertion of notes with one hand and simplifies the note handling mechanism.

INTERFACE

Interfacing the validator is very simple, with the choice of the following protocols:

SSP	eSSP	ccTalk	MDB
Parallel	Pulse	Binary	SIO

Table 4 - Available Interfaces/Protocols

For detailed information about the different interfaces see chapter 4.3.

PC SYSTEM SPECIFICATION

The ITL Validator Software has been tested and verified using Windows 2000/XP/Vista™ (32bit versions only) on a Pentium™ based PC System (© Microsoft and Intel). Full functionality cannot be guaranteed on lower specification systems.



4 MACHINE INTERFACES

4.1 BEZEL LEDs

The Bezel LED's are used to indicate a variety of status signals as described below.

Number of LONG flashes	Number of SHORT flashes			
	1	2	3	4
1		Note Path Jam	Unit Not Initialized	
2				
3	Firmware Checksum	Interface checksum	EEPROM Checksum	Dataset Checksum
4	PSU too Low	PSU too High		

Table 5 - Bezel LED Status Codes

4.2 HARDWARE

4.2.1 PORTS AND BUTTONS

The NV9 USB interface connector is located on the left side of the unit; it has 16 pins (see Figure 2), refer to Table 6 for the pin allocation. Two are used for the 0V and +12V power supply and there are five outputs and five inputs, the remaining four pins are reserved for the USB connection and factory use. An example mating connector is Molex type Part No: 39-51-2160. To take advantage of the USB connectivity, a USB cable (CN392) should be used. The USB cable CN392 fits into the 16 way connector, this can be used for high speed programming and serial communications when used in SSP and SIO modes. When using the USB connection, power must be applied to the NV9 USB via the 16 pin interface connector using CN392.

A driver file will be required on the computer when connecting to the NV9 USB using the USB connector. The file required is ITLUSBser.inf and can be downloaded from the Support section of the ITL website - NV9 USB & NV10 USB Driver Install.

The NV9 USB also has a Configuration Button located on the top of the unit. The configuration button has a number of functions as described in chapter 4.2.3



4.2.2 INTERFACE CONNECTOR PIN DETAILS

The connector pin details are described below (see Table 6); they use an IDC 16-pin 0.1" pitch header with 2 rows of 8 pins.

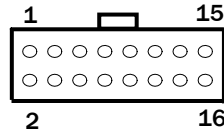

Figure 2 - Pin Detail

CONNECTIONS

Pin	Name	Description
1	Vend 1	Open collector outputs. Function changes depending on machine interface protocol (see individual interface descriptions for details.) Also the Pulse Steam output. Also the Serial Output pin in SSP Serial Mode and other serial modes.
2	Vend 2	Open collector outputs. Function changes depending on machine interface protocol (see individual interface descriptions for details).
3	Vend 3	Open collector outputs. Function changes depending on machine interface protocol (see individual interface descriptions for details).
4	Vend 4	Open collector outputs. Function changes depending on machine interface protocol (see individual interface descriptions for details).
5	Inhibit 1	Inhibit channel 1 by holding this pin HIGH. To Enable a channel the inhibit must be held LOW. Also the serial Input pin in SSP Serial Mode, and other serial modes.
6	Inhibit 2	Inhibit channel 2 by holding this pin HIGH
7	Inhibit 3	Inhibit channel 3 by holding this pin HIGH
8	Inhibit 4	Inhibit channel 4 by holding this pin HIGH
9	Busy	NV9 USB is validating and stacking output. Active low while the NV9 USB is reading, transporting or stacking a note
10	Escrow	Operate Escrow function by holding LOW (see Appendix B – Escrow Control for full details).
11	USB	Data Plus
12	USB	Data Minus
13	USB	-V- Bus
14	Factory use only	Do Not Connect
15	+Vin	Nominal 12V DC supply
16	0V	0V supply

Table 6 - 16 Pin Connector Details



4.2.3 CONFIGURATION BUTTON FUNCTIONS

The functions available via the Configuration Function Button are detailed in Table 7.

Action	Power Status	Function
Press and Hold until the bezel illuminates (>2 secs) then release	Powered ON	Sets NV9 USB to Programming Mode (SSP)
Press Once (<1 sec)	Powered ON	Enables Configuration Card Programming. Pressing the button again cancels this mode
Press Twice (within half a second)	Powered ON	Current Setting Indicator
Press and hold as power is applied	Powered OFF/ON	Resets ccTalk key to Default setting

Table 7 - Configuration Button Functions

NV9 USB PROGRAMMING MODE

Press and Hold the Configuration Button for approximately 2 seconds whilst the NV9 USB is powered up until the bezel LED illuminates. The Bezel LED will flash rapidly as the button is released to indicate that SSP is being loaded. Once this process has finished the NV9 USB will reset. The NV9 USB will now be in Programming Mode (SSP) and allow connection to a PC via a DA2 adapter or connection to a DA3. Pressing and holding the button again will return the NV9 USB to its original interface. It is advisable to check the current mode using the double press Current Setting Indicator Mode

CONFIGURATION CARD PROGRAMMING MODE

Press the Configuration Button once whilst the NV9 USB is powered up. If done correctly the Bezel LED will flash every 1 second. This will allow the insertion of a Configuration Card to change the Firmware Protocol in the NV9 USB. (See Chapter 4.4 for full details). This mode can be cancelled by again pressing the Configuration Button once.

CURRENT SETTING INDICATOR MODE

Press the Configuration Button twice within half a second whilst the NV9 USB is powered up. The NV9 USB Bezel LED will then perform a series of flashes to indicate the current settings within the validator. (See Program Check Procedure, Appendix C – Configuration Cards)

ENCRYPTION KEY RESET FUNCTION (CCTALK®)

Note: This function will only be possible if the NV9 USB is programmed to ccTalk® mode. It is not possible to reset the key from SSP mode. Press and hold the Configuration Button whilst the NV9 USB powered is off. Apply the power and keep the button pressed for several seconds. Release the button and the ccTalk Encryption key will now be restored to the default setting.



4.3 PROTOCOLS

ITL strongly recommends the use of an encrypted Serial protocol (Preferably eSSP) to achieve the highest security.

4.3.1 eSSP - ENCRYPTED SMILEY® SECURE PROTOCOL

We have now developed encrypted SSP for the NV9 USB banknote validator as it is our opinion that encrypted SSP is now necessary in this advanced technological age. The encryption of SSP protocol will ensure superior protection and reliability of the data, which is transferred between validator and host machine. The encryption key is 128 bits long, and is divided into two parts. The lower 64 bits are fixed and specified by the machine manufacturer, allowing the manufacturer to control which devices are used in their machines. The higher 64 bits are securely negotiated by the slave and host at power up, ensuring each machine and each session are using different keys. This encryption algorithm is approved by the US military for its advanced security.

We have new hardware interfaces available to enable eSSP banknote validators to be used in machines without the need of updating the machine software. The interface is mounted close to the control board, and converts the connection to the banknote validator to serial eSSP, giving maximum security along the length of the cable.

CONNECTIONS

Pin	Name	Type	Description
1	Vend 1	Output	Serial Data Out (Tx)
2	Vend 2	Output	Not Used
3	Vend 3	Output	Not Used
4	Vend 4	Output	Not Used
5	Inhibit 1	Input	Serial Data In (Rx)
6	Inhibit 2	Input	Not Used
7	Inhibit 3	Input	Not Used
8	Inhibit 4	Input	Not Used
9	Busy	Output	Not Used
10	Escrow	Input	Not Used
11	USB D+	Data	USB Data +
12	USB D-	Data	USB Data -
13	USB Vcc	Power	USB Vcc (+5V)
14	Factory Use Only		Do not connect
15	+Vin	Power	Nominal 12V DC supply
16	0V	Ground	0V supply

Table 8 - eSSP Connection details

When connecting via the USB connections, 12 V must be supplies to pin 15 and 0V connected to pin 16.



4.3.2 SMILEY® SECURE PROTOCOL - SSP

NOTE: Please refer to the Smiley® Secure Protocol (SSP) Specification (ITL Drawing GA138) on the web site for full details of the SSP protocol. To use SSP mode, the SSP interface must be programmed into the validator via the Configuration Cards (See Appendix C – Configuration Cards) or via the ITL BNV Currency Manager Program, or by pressing and holding the Configuration Button for more than 2 seconds.

SSP is a secure serial interface specifically designed to address the problems experienced by cash systems in gaming machines. Problems such as acceptor swapping, reprogramming acceptors and line tapping are all addressed. This interface is recommended for all new designs. The interface uses a master slave model; the host machine is the master and the peripherals (note acceptor, coin acceptor or coin hopper) are the slaves. Data transfer is over a multi-drop bus using clock asynchronous serial transmission with simple open collector drivers.

The integrity of data transfers is ensured through the use of 16 bit CRC checksums on all packets. Each SSP device of a particular type has a unique serial number; this number is used to validate each device in the direction of credit transfer before transactions can take place. Commands are currently provided for coin acceptors, note acceptors and coin hoppers. All current features of these devices are supported.

For detailed information and full protocol specification please refer to SSP Interface Specification ITL (GA138), this is available from the A.u.S. website www.aus.at

Connections for SSP are the same as for eSSP

SSP CONFIGURATION CARD OPTIONS

When using the configuration card to set SSP mode, the following options are available:

- Note inhibits – fill in the boxes to inhibit notes

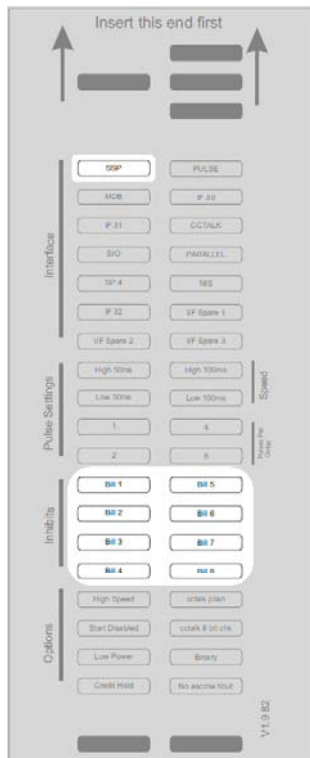

To help in the software implementation of the SSP, ITL can provide DLL controls and Visual Basic applications on request. Please contact technik@aus.at for more information.

Figure 3 - SSP Configuration Card Options



4.3.3 CCTALK® PROTOCOL - CCT

The NV9 USB supports the ccTalk serial protocol for easy interfacing with host machines that support this protocol. To use ccTalk® mode, the CCT interface must be programmed into the validator via the Configuration Cards (See Appendix C – Configuration Cards) or via the ITL BNV Currency Manager Program.

Pin out connections on NV9 USB for ccTalk are shown (see Figure 4) looking at the connection pins on the NV9 USB interface connector as defined in the ccTalk specification. It is recommended that all communications with the note validator must be encrypted using the encryption key, the default encryption key will be printed on the label of the NV9 USB. To reset the Encryption key to its default value see Chapter 4.2.3.

NOTE: For detailed information and full protocol specification, please refer to www.cctalk.org.

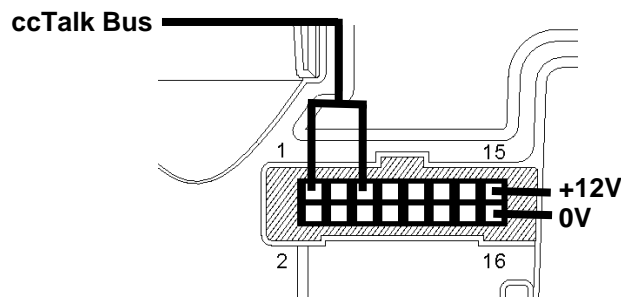

Figure 4 - ccTalk pin connection diagram

CONNECTIONS

Pin	Name	Type	Description
1	Vend 1	Output	Serial Data – Must also be connected to pin 5
2	Vend 2	Output	Not Used
3	Vend 3	Output	Not Used
4	Vend 4	Output	Not Used
5	Inhibit 1	Input	Serial Data – Must also be connected to pin 1
6	Inhibit 2	Input	Not Used
7	Inhibit 3	Input	Not Used
8	Inhibit 4	Input	Not Used
9	Busy	Output	Not Used
10	Escrow	Input	Not Used
11	USB D+	Data	USB Data +
12	USB D-	Data	USB Data -
13	USB Vcc	Power	USB Vcc (+5V)
14	Factory Use Only		Do not connect
15	+Vin	Power	Nominal 12V DC supply
16	0V	Ground	0V supply

Table 9 - ccTalk connection details

When connecting via the USB connections, 12 V must be supplies to pin 15 and 0V connected to pin 16.



CCTALK CONFIGURATION CARD OPTIONS

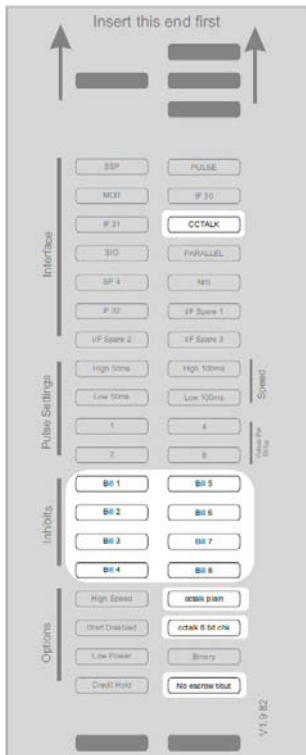

When using the configuration card to set SSP mode, the following options are available:

- Note Inhibits – fill in the boxes to inhibit notes
- ccTalk plain – fill in this box to use un-encrypted ccTalk
- ccTalk 8 bit chk – if ‘ccTalk Plain’ is selected, leave this box blank for 16 bit CRC checksum. Fill in this box to use simple 8 bit checksum
- No escrow t/out – fill in this box to disable the escrow timeout

Figure 5 - ccTalk Configuration Card Options

4.3.4 MULTI-DROP BUS/INTERNAL COMMUNICATIONS PROTOCOL (MDB/ICP)

To use the MDB mode an IF5 interface box must be used. The MDB interface must also be programmed into the validator via the Configuration Cards (See Appendix C – Configuration Cards) or via the ITL BNV Currency Manager program.

Notes:

- NV9 USB can only be used in MDB with the addition of an IF5 interface.
- Please refer to the Multi-Drop Bus specification for the suggested current drive circuits available.
- The NV9 USB supports the MDB protocol version 1, level 1.
- For detailed information and full protocol specification please refer to www.vending.org

MDB is a 9600 Baud Master-Slave system where the NV9 USB Banknote Validator is a slave to a master controller. A master has the capability of communicating with 32 peripherals or slaves. The master is defined as the Vending Machine Controller (VMC). The NV9 USB banknote Validators have a unique address – 00110XXX binary (30H). The VMC polls the bus to detect presence of the NV9 USB Validator or get information on the current status of the validator.

The validators will respond when asked for activity with an acknowledgment, a negative acknowledgment or a specific reply, depending on its current status. Bus crashes are avoided as the Validators respond to being polled only by the VMC.



The international country code must be set for the country in which the Validators will be operating. This is either the international telephone code for that country, or the country code taken from ISO4217. The code is represented as two bytes. The initial digit signifies the source of the code. 0 signifies the telephone code is used, 1 signifies ISO4217 has been used.

For the USA the country code is 00 01, or 18 40
 For Great Britain the code is 00 44, or 18 26.

The scaling factor must also be specified for each Validator. All accepted note values must be evenly divisible by this number.

- This number would be set to 100 (Hex 64) for the Euro or Great Britain.
- The number would be set to 1000 (Hex 03E8) for Colombia.

The number of decimal places must also be programmed for each Validator

- The number would be set to 2 for Euro or USA
- The number would be set to 3 for Colombia

Adopting the numbers above.

- £5 would be displayed as 5.00
- £10 would be displayed as 10.00
- \$1 would be displayed as 1.00
- 1K Colombia would be displayed as 1.000

MDB CONFIGURATION CARD OPTIONS



When using the configuration card to set MDB mode, the following options are available:

- Note inhibits – fill in the boxes to inhibit notes

Figure 6 - MDB Configuration Card Options



4.3.5 PARALLEL

In parallel mode the NV9 USB will issue a 100ms ($\pm 3\%$) active LOW pulse on the relevant vend line. A maximum of 4 channels can be used.

CONNECTIONS

Pin	Name	Type	Description
1	Vend 1	Output	Channel 1 credit, 100ms active low pulse
2	Vend 2	Output	Channel 2 credit, 100ms active low pulse
3	Vend 3	Output	Channel 3 credit, 100ms active low pulse
4	Vend 4	Output	Channel 4 credit, 100ms active low pulse
5	Inhibit 1	Input	Inhibit Channel 1 by holding this pin HIGH
6	Inhibit 2	Input	Inhibit Channel 2 by holding this pin HIGH
7	Inhibit 3	Input	Inhibit Channel 3 by holding this pin HIGH
8	Inhibit 4	Input	Inhibit Channel 4 by holding this pin HIGH
9	Busy	Output	Busy signal - output is pulled low while the validator is busy
10	Escrow	Input	Hold this pin LOW to enable the Escrow function
11	USB D+	Data	USB Data +
12	USB D-	Data	USB Data -
13	USB Vcc	Power	USB Vcc (+5V)
14	Factory Use Only		Do not connect
15	+Vin	Power	Nominal 12V DC supply
16	0V	Ground	0V supply

Table 10 - Parallel Connection Details

In Parallel mode, there is the option to use a binary output where the NV9 USB will output a binary pattern on vend lines 1 - 4. Binary mode can be set as an option using the configuration cards or with the ITL BNV Currency Manager software.



PARALLEL MODE CONFIGURATION CARD OPTIONS

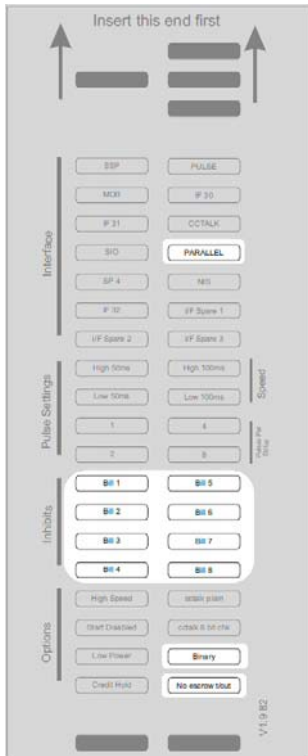

When using the configuration card to set parallel mode, the following options are available:

- Note inhibits – fill in the boxes to inhibit notes
- Binary – fill in this box to enable binary output mode
- No escrow t/out – fill in this box to disable the escrow timeout

Figure 7 - Parallel Configuration Card Options



4.3.6 PULSE

In Pulse mode the NV9 USB outputs a number of pulses on Vend 1. The number of pulses for each channel is different and set to default values within the dataset. The number of pulses and the pulse duration can be modified using the Bank Note Validator Currency Manager Software. A pulse multiplier can be set using the configuration card. A maximum of 16 channels can be used.

CONNECTIONS

Pin	Name	Type	Description
1	Vend 1	Output	Credit pulse stream output
2	Vend 2	Output	Not Used
3	Vend 3	Output	Not Used
4	Vend 4	Output	Not Used
5	Inhibit 1	Input	Inhibit Channel 1 by holding this pin HIGH
6	Inhibit 2	Input	Inhibit Channel 2 by holding this pin HIGH
7	Inhibit 3	Input	Inhibit Channel 3 by holding this pin HIGH
8	Inhibit 4	Input	Inhibit Channel 4 by holding this pin HIGH
9	Busy	Output	Busy signal – output is pulled low while the validator is busy
10	Escrow	Input	Hold this pin LOW to enable the Escrow function
11	USB D+	Data	USB Data +
12	USB D-	Data	USB Data -
13	USB Vcc	Power	USB Vcc (+5V)
14	Factory Use Only		Do not connect
15	+Vin	Power	Nominal 12V DC supply
16	0V	Ground	0V supply

CREDIT HOLD FUNCTION

If this function is enabled in pulse mode by Configuration card or ITL BNV Currency Manager Program, the validator will take the note as normal but then wait until the escrow line is toggled low/high. It will then give out the number of pulses per dollar as set on the programming card. After the pulses have been given, the validator will then wait for another low/high toggle until the full value of credit pulses are given.

For example with a setting of 4 pulses per dollar, a five dollar bill will give 4 pulses, 5 times.

A Typical use of this option would be for a Pool table with a game price of \$1. You could insert a \$5 note and press a button that toggles the escrow line and releases the pool balls, this would then allow you to play the first game. The Validator holds onto the remaining credits until the game has finished and the button is pressed again allowing the next game to begin, this continues until all the credits have been used.

The busy line remains low throughout the whole process and the validator remains inhibited until all pulses are given.



PULSE MODE CONFIGURATION CARD OPTIONS



When using the configuration card to set pulse mode, the following options are available:

- Pulse Settings – Select the required pulse widths and the pulse multiplier
- Note inhibits – fill in the boxes to inhibit notes
- Credit Hold – fill in this box to enable the credit hold function

NOTE:

The SP4 option is identical to Pulse mode but the NV9 USB will always be enabled. It is not necessary to set the inhibits to enable the NV9 USB.

Figure 8 - Pulse Configuration Card Options



4.3.7 SERIAL INPUT/OUTPUT – SIO

Existing Smiley® NV4 - NV10 users may already be using the serial input/output facility. The NV9 USB Validator also supports this system. However this interface is not recommended for new designs, the Smiley® Secure Protocol SSP interface is recommended.

CAUTION

- The host machine does not echo messages back to the validator.
- The NV9 USB does not operate in true RS232 mode. (Only TTL level).
- To use Serial Input/Output mode, the SIO interface must be programmed into the validator via the Configuration Cards (See Appendix C – Configuration Cards) or via the ITL BNV
- Currency Manager Program.

There are 4 different options available:

- 300 Baud (default)
- 9600 Baud
- Start Disabled
- Serial Output Only (compatible with the older NV4 serial output/Parallel input mode)

CONNECTIONS

Serial Input Serial Output mode

Pin	Name	Type	Description
1	Vend 1	Output	Serial Data
2	Vend 2	Output	Not Used
3	Vend 3	Output	Not Used
4	Vend 4	Output	Not Used
5	Inhibit 1	Input	Serial Data
6	Inhibit 2	Input	Not Used
7	Inhibit 3	Input	Not Used
8	Inhibit 4	Input	Not Used
9	Busy	Output	Not Used
10	Escrow	Input	Not Used
11	USB D+	Data	USB Data +
12	USB D-	Data	USB Data -
13	USB Vcc	Power	USB Vcc (+5V)
14	Factory Use Only		Do not connect
15	+Vin	Power	Nominal 12V DC supply
16	0V	Ground	0V supply

Table 11 - SIO Connection Details

When connecting via the USB connections, 12 V must be supplies to pin 15 and 0V connected to pin 16.



Serial Output, Parallel input mode

Pin	Name	Type	Description
1	Vend 1	Output	Serial Data
2	Vend 2	Output	Not Used
3	Vend 3	Output	Not Used
4	Vend 4	Output	Not Used
5	Inhibit 1	Input	Inhibit Channel 1 by holding this pin HIGH
6	Inhibit 2	Input	Inhibit Channel 2 by holding this pin HIGH
7	Inhibit 3	Input	Inhibit Channel 3 by holding this pin HIGH
8	Inhibit 4	Input	Inhibit Channel 4 by holding this pin HIGH
9	Busy	Output	Busy signal – output is pulled low while the validator is busy
10	Escrow	Input	Not Used
11	USB D+	Data	USB Data +
12	USB D-	Data	USB Data -
13	USB Vcc	Power	USB Vcc (+5V)
14	Factory Use Only		Do not connect
15	+Vin	Power	Nominal 12V DC supply
16	0V	Ground	0V supply

Table 12 - Serial Output Parallel Input Connection Details

SIO MODE CONFIGURATION CARD OPTIONS

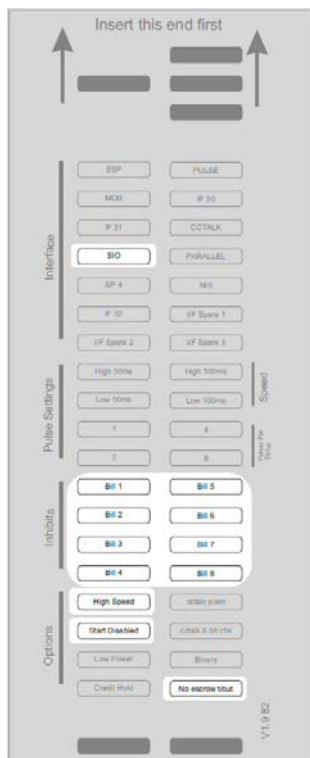

When using the configuration card to set SIO mode, the following options are available:

- Note inhibits – fill in the boxes to inhibit notes
- High Speed – fill in this box to use 9600 baud
- Start Disabled – When this box is filled in, the NV9 USB will start up in the disabled state
- No escrow t/out – fill in this box to disable the escrow timeout

Figure 9 - SIO Configuration Card Options



4.4 USING NV9 USB CONFIGURATION CARDS

The Configuration Cards offer the following functions:

- Select required Communication Interface (SSP, ccTalk, Parallel etc).
- Adjust the channel and pulse configuration on a pre-programmed NV9 USB to your own requirements.

Programming the NV9 USB with the configuration cards is enabled via the 'Configuration Button' on the right hand side of the NV9 USB (see Chapter 4.2.3). (For details on how to complete the configuration cards please see Appendix C – Configuration Cards)

Instructions:

- Press the Configuration button once whilst the validator is powered up.
- The bezel LEDs will now flash with a steady heartbeat until a Configuration Card is entered.
- Once the Configuration Card has been entered the validator reads the card and immediately returns it.
- The LEDs then flash rapidly whilst the interface is being changed. If the LEDs flash a number of times slowly, it is an indication of an error (For details of the Error Flash Codes please see Appendix D – Configuration Cards).
- When the changes are complete the validator resets.

If a configuration card is not entered, this function can be cancelled by pressing the button again once.

It is possible to check the programmed settings of the NV9 USB by pressing the Configuration button twice within half a second. (For details see Appendix C – Configuration Cards)



5 MECHANICAL

5.1 CHANGING OR REMOVING THE BEZELS

The NV9 USB validators can be supplied with various bezel options as shown in

- Push both of the red locking arms so that they disengage from the bezel sides.

The bezel may then be unhooked from the 6 locating points, (see

- Figure 10).
- To refit push the bezel onto the six locating points (3 each side).
- The red locking arms will spring back to secure the bezel

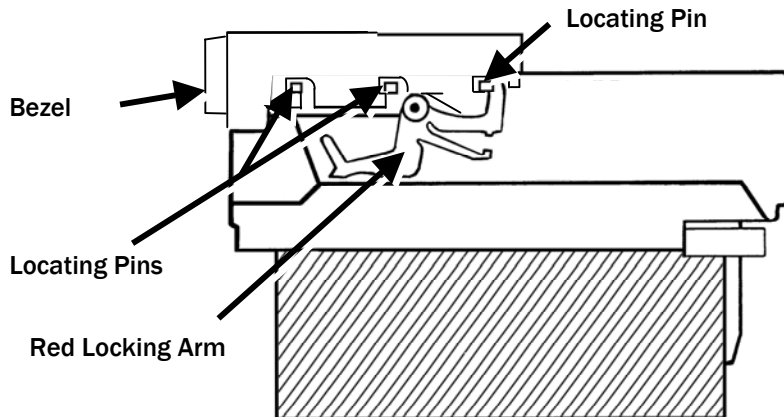

Figure 10 - Bezel and NV9 USB Installation

CAUTION:

- ALWAYS MAKE SURE THAT **BOTH** THE LOCKING ARMS HAVE FULLY LOCATED IN TO PREVENT DAMAGE.

5.2 CASH BOX OPTIONS

The NV9 USB validators can be supplied with various cash box options, shown in Appendix G – Cash Boxes.



Figure 11 - Clip On and Slide In Cash Boxes

- 300 Note Clip on (part no PA185) for the vertical bezel options only.
- 300 Note Slide in (part no PA192) for both the horizontal and vertical bezel options.
- 600 Note Clip on (part no PA193) for the vertical bezel options only.
- 600 Note Slide in (part no PA194) both the horizontal and vertical bezel options.
- 300 Note Lockable for the horizontal bezel option only (part no PA186). (Lock is not supplied – use with Baton Lock type 6086-00KAL06 with supplied cam)



6 ROUTINE MAINTENANCE

The NV9 USB Validator has been designed to minimise any performance variation over time. Much of this is achieved by careful hardware and software design. However, depending upon the environment the NV9 USB may at some time require cleaning, belt changing or note path clearing.

6.1 CLEANING

CAUTION: DO NOT USE SOLVENT BASED CLEANERS SUCH AS ALCOHOL, PETROL, METHYLATED SPIRITS, WHITE SPIRIT or PCB CLEANER. THIS WILL RESULT IN PERMANENT DAMAGE TO THE VALIDATOR, ONLY USE A MILD DETERGENT.

To clean, slide the red release catch on the end of the NV9 Validator to the left, to open the note path. The note path and lozenge are now exposed for cleaning.

Carefully wipe the surfaces with a soft lint free cloth that has been dampened with a water and mild detergent solution (i.e. household washing up liquid). Take particular care around all the sensor lenses (see Figure 12) ensuring they are clean and dry. If a lens has become badly scratched do not attempt to polish it. Contact ITL for further advise, as there may be damage to the optical properties of the lens.

CAUTION: WHEN CLEANING THE "RECESSED" FRONT SENSOR, USE A SMALL SOFT BRUSH OR COTTON WOOL BUD.

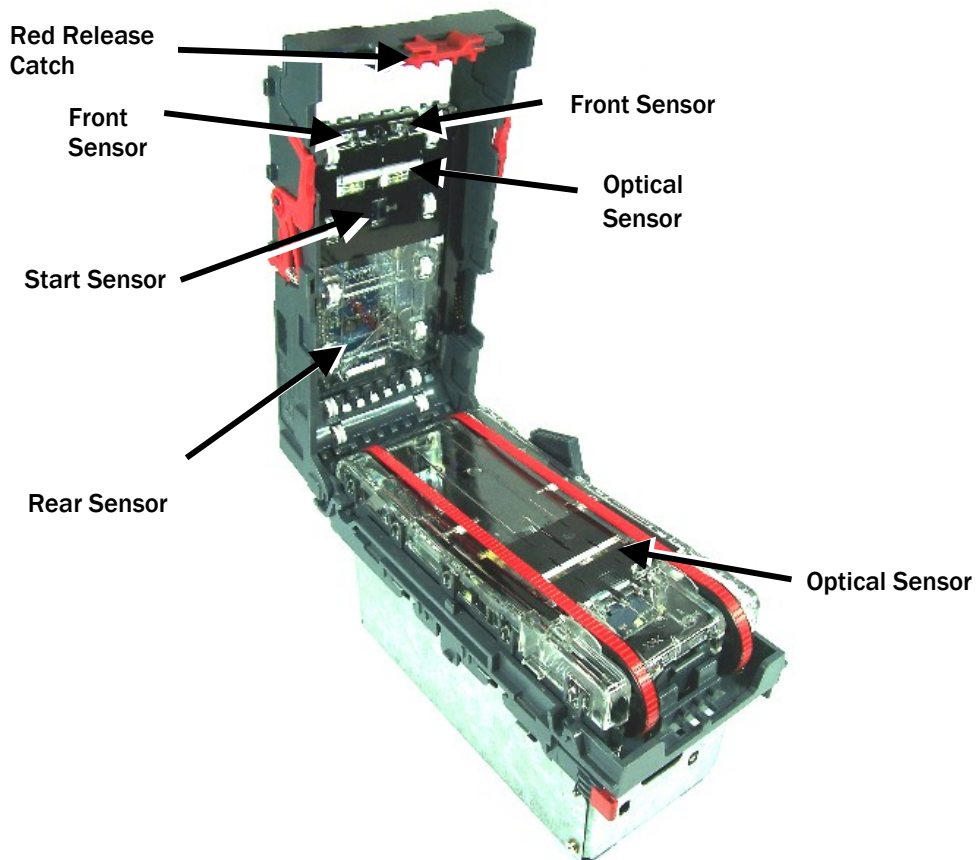

Figure 12 - NV9 USB Sensor Location

6.2 BELT CLEANING

- Ensure the validator is enabled (i.e. Bezel lights are illuminated)
- Remove Bezel.
- Insert a piece of paper, which is narrower than the width between the two belts, in the centre of the note path to activate the drive motor.
- Use a lint free cloth dampened with water containing a mild detergent such as dish detergent and hold it against each drive belt as it turns.
- Repeat steps 3 and 4 until all dust and debris has been removed from both belts.
- Repeat step 3 using a DRY lint free cloth to remove any excess moisture.

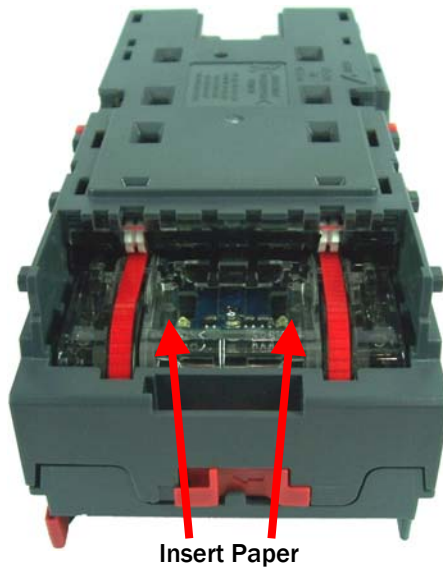

Figure 13 - Belt Access

6.3 DEBRIS CLEARING

- Examine the note paths, lozenge and note stacker for any dirt or debris.
- Carefully clear and wipe the surfaces of the note paths and lozenge with a soft lint free cloth that has been dampened with a water and mild detergent solution (i.e. household washing up liquid.). Take particular care around all the sensor lenses (see Figure 12), ensuring they are clean and dry.
- Check that the note stacker and cash box spring plate are not jammed.

6.4 BELT CHANGING

- Open the top of the unit using the “Red Release Catch”
- Release the lozenge by gently pressing the “Lozenge Release Catch” (see Figure 14).
- Remove and place the lozenge on a clean dry surface
- Remove the belts, sliding them off the smallest wheels first.
- Replace the belts by fitting them over the lozenge, largest wheels first.
- Reassemble and close the unit.

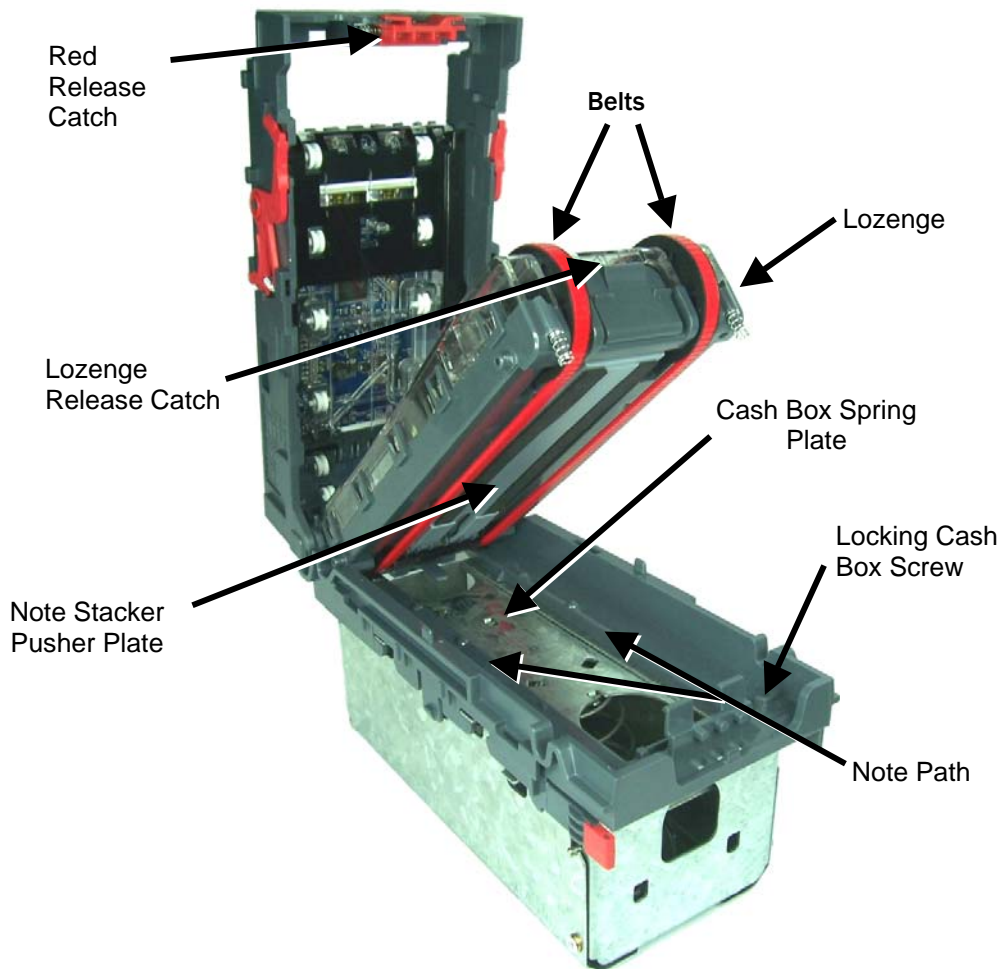

Figure 14 - Belt Removal

NOTE: With the Locking Cash Box, the Locking screw must be removed first.

6.5 RE-CALIBRATION

The NV9 USB has an in-built self-calibration system that maintains the optical sensors at their best operating point.

However if the NV9 USB is disassembled for any reason it will need to be re-calibrated. Re-calibration may only be performed under license from ITL, contact support@innovative-technology.co.uk for further details.

7 DIAGNOSTICS

Symptom	Possible Cause	Corrective Action
All notes are rejected (Bezel LED's are on)	Incorrect currency file programmed	Check that the required dataset is programmed into the validator using the validator manager software.
	Notes are not included in the currency file	Check that the required note denomination and issue is included in the currency file using the validator manager software.
	Notes are inhibited by the host machine	Ensure the machine is ready to accept notes. If a coin hopper is in the machine, ensure it is not empty. Ensure the maximum allowed credit on the host machine has not been exceeded.
	Bill path obstructed	Check for necessary clearance for note ejection after acceptance.
Notes are not taken in (no bezel LED's)	No Power	Ensure the correct specification of power is applied to the validator.
	Incorrect interface is programmed	Check which interface is programmed into the validator by double clicking the configuration button. The displayed code indicates which interface is programmed as described in Appendix C – Configuration Cards)
	Incorrect interface is programmed	Check which interface is programmed into the validator by double clicking the configuration button. The displayed code indicates which interface is programmed as described in document number GA713.
Notes accepted but no credit given	Power supply outside specification	Ensure correct supply and sufficient current. Also check for necessary clearance for note ejection after acceptance.
	Rear note detect sensor obscured	Ensure no foreign objects are obstructing the sensors.
Acceptor runs slowly or intermittently	Foreign objects in the note path	Clean the note path
	Incorrect voltage level of supply	Ensure correct supply and sufficient current
	Damage in the unit	Replace necessary components
Bezel LED's are flashing	See chapter 4.1 for details of LED status signals	
Motor continues to run	Foreign object or note is stuck in the note path	Ensure the note path is clear and reset the validator. It may also be necessary to reset the host machine.

Table 13 - NV9 USB Fault finding



8 SUPPORT

The following support tools are available for use with the NV9 USB Bank Note Validator:

- Configuration Cards.
- ITL Bank Note Validator Currency Manager Software.
- ITL Diagnostic Tools
- Validator Programming System (DA3)
- Downloads from the Innovative Technology Ltd website:
www.innovative-technology.co.uk
- E-mail Support via support@innovative-technology.co.uk

CONFIGURATION CARDS

For full details of the use and function of the Configuration Cards please see Appendix C – Configuration Cards.

ITL BANK NOTE VALIDATOR CURRENCY MANAGER

The ITL BNV Currency Manager software offers the following functions:

- Program the Validator by downloading pre-prepared currency/firmware file via the DA2 kit.
- Check the firmware version and currency set already loaded on a NV9 USB unit.
- Adjust the channel and pulse configuration on a pre-programmed NV9 USB to your own requirements.

The software will run or equivalent (see the General Description chapter for operating system requirements). The NV9 USB can be connected directly via the USB port, or with a DA2 kit.

NOTE:

- The Validator must be set to Programming Mode (SSP) when connected to a computer or DA3 and then returned to the original settings when complete (See Chapter 4.2.3).
- ITL BNV Currency Manager 3.3.9 or Higher must be used to access the NV9 USB functions.

ITL DIAGNOSTIC TOOLS

- A Diagnostic program to check the NV9 USB operation

VALIDATOR PROGRAMMING SYSTEM (DA3)

The DA3 is a programming system designed to enable the programming of ITL Bank Note Validators in the field without the use of a PC.

Once the DA3 has been programmed the user can:

- Update the existing dataset and firmware with the latest versions using the BNV Match Download function
- Reprogram the validator to accept a different currency using the BNV Override Download function.
- Test the functionality of the validator away from the Host machine.

For full DA3 operation and functionality details please refer to the DA3 User Manual (Document number GA339)

NOTE:

When programming a NV9 USB using the DA3 BNV Override Download function, the firmware interface will not be changed. If a different interface is required, the user must use a configuration card to select the required interface.



INTERNET WEBSITE SUPPORT

The A.u.S. website provides the means to download new and updated currency sets and new versions of firmware for the NV9 USB. You can obtain these along with technical bulletins by visiting www.aus.at

E-MAIL SUPPORT

If the data you require is not available over the Internet, A.u.S. supports an e-mail system to help customers with unusual requirements. The address is: technik@aus.at



APPENDIX A – HOW TO ORDER A NV9 USB VALIDATOR

To order a validator, please print and fill the order form, presented in the next page, and send it to our nearest office. You may send it by fax or email. To find our contact information, please go to our website or refer to the introduction chapter in this document. If you do not know which office to send the order form, send it to our main headquarter:

A.u.S. Spielgeräte GmbH
 Derker Street – Oldham – England - OL1 4EQ
 Tel: +43 (0)1 2716600 Fax: +43 (0)1 271660075
 E-mail: verkauf@aus.at
 Web site: www.aus.at

If you have any questions about the information required for the order form, please see chapter 3, General Description. If you still have any questions, or you want to know more about other products and possibilities, do not hesitate to contact your nearest dealer. We offer a wide range of products and accessories such as alternative validators, programming kits, interfaces, connecting cables, bezels and other elements. Please contact your nearest office for more information.

NV9 USB

Date:

Company Details

Company: Phone Number:

Contact Person: Country:

Issue Number: Customer Part Number:

	NV9 USB			
Product				
Dataset				
Firmware Version				
Firmware Interface				
CcTalk key				

APPROVED

Customer: A.u.S.Spielgeräte:



APPENDIX B – DIMENSION DRAWING

A	300 SLIDE-IN CASH BOX
B	600 SLIDE-IN CASH BOX
C	1000 SLIDE-IN CASH BOX

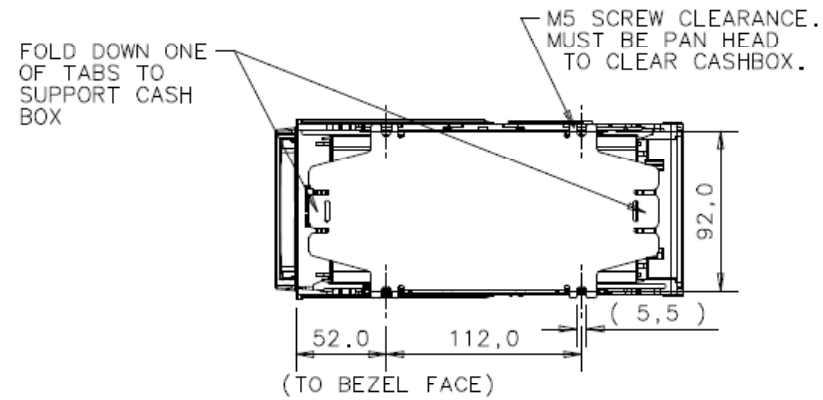
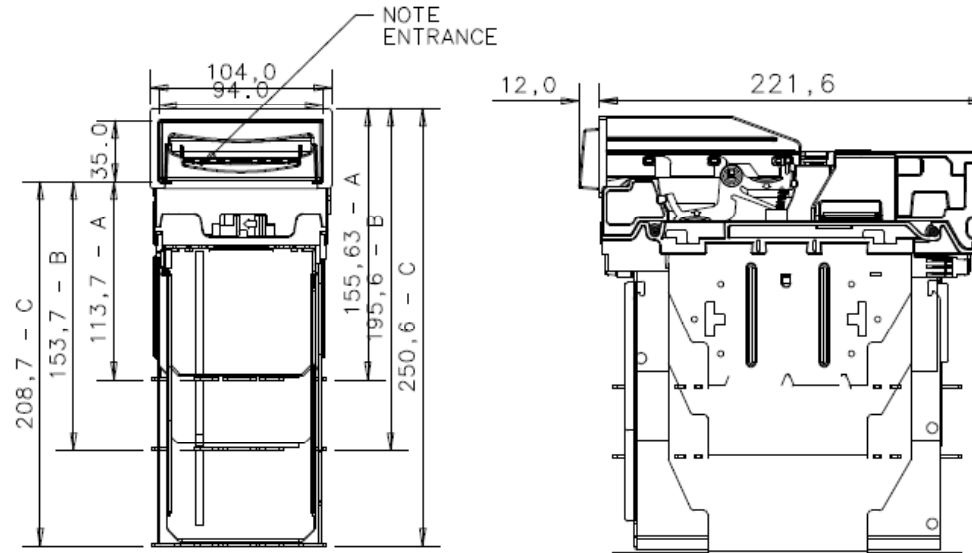

APPENDIX C – CONFIGURATION CARDS

The following pages contain the information corresponding to the document number GA713. To print the card on the last page of this manual, ensure that the page scaling is set to 'none'. Always ensure that the card has printed with the correct dimensions before use. If using the cards contained within GA713, the 82mm card must be used.

NOTE:

Not all options printed on the configuration card are relevant to the NV9 USB. The configuration cards can be used for other products within the ITL range of note readers. See the specific product manual for the appropriate product interfaces.

CONFIGURATION OPTION PROGRAMMING

- Select correct width card for bezel. Cut card around outline – check measurements as printed. Check print options 'Page scaling' is set to 'none' when printing a pdf file to ensure correct size.
- Fill in sections as required. Take care to fill in the selections correctly, keep inside the lines and fill boxes fully as example below.
- Power up NV9 USB and allow it to reset.
- Click the configuration button on the NV9 USB to access Configuration Mode, the bezel LEDs should be flashing at 1 second intervals.
- Enter card into NV9 USB in direction indicated by arrows.
- Card will be returned and if configuration was good the bezel LEDs will flash rapidly while programming takes place. Take care to ensure the power is not removed at this stage; the NV9 USB may suffer permanent damage!! The NV9 USB will then reset.
- If an error occurs has occurred the card will be rejected and the bezel LEDs will flash slowly a number of times to indicate the cause of the error. (See table below)
- Important check that the configuration requested has been set in the NV9 USB before use.

Flash	Error
2	Invalid card read – card entered wrong way round, card mis-read or card wrong version
3	No interface selection was detected on card
4	Multiple interface selections detected
5	Invalid interface selected – the selected interface is not available for this NV
6	Selected interface not compatible with NV version
7	Pulse configuration error. Selected pulse options invalid.
8	ccTalk configuration error. Selected cctalk options invalid (ccTalk 8 bit chk not allowed without ccTalk Plain)
9	Low power mode not available on this NV version

Table 14 - Configuration Card Error Codes



PROGRAM CHECK PROCEDURE

To check settings on a programmed unit:

1. Power on unit
2. Click program set button on unit twice (like double click on mouse)
3. Monitor bezel led and check flash codes

	Flash count	Pulse high	Pulse low	Pulse per dollar	High speed	Disabled	ccTalk plain	Low power	Binary	Credit hold
SSP	1									
Pulse	2	ms/10	ms/10	value						3 flash
MDB	3									
IF30	4									
IF31	5									
ccTalk	6						1 flash			
SIO	7				1 flash	2 flash				
Parallel	8								1 flash	
spare	9									
NIS	10									
IF32	11				1 flash					
spare	12									
spare	13									
spare	14									

Table 15 - NV9 USB program Check Bezel Codes

For example:

A pulse interface with 50ms high, 100ms low, 1 pulse per dollar will flash 2,5,10,1

A SSP interface will only ever flash once

A ccTalk interface with 16 bit checksum, no encryption will flash 6,1

A ccTalk interface with 8 bit checksum, no encryption will flash 6,1,2

A Binary interface will flash 8,1



APPENDIX D – ESCROW CONTROL

The NV9 USB has a single note escrow facility (pin 10) used in Parallel, Pulse and Binary modes. This allows the Validator to hold onto the note once accepted, and then only stack the note into a cash box when the host machine confirms that the Vend operation has been completed. If no confirmation of the Vend is received then the note will be returned to the customer after 30 seconds, (see Figure 15 - Escrow Timing Diagram for Parallel Vends).

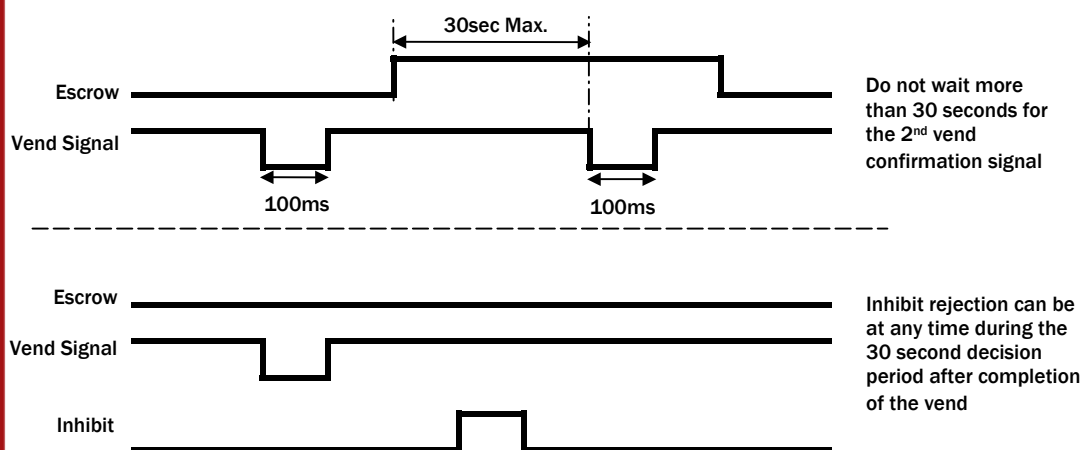

Figure 15 - Escrow Timing Diagram for Parallel Vends

If the host machine itself aborts the transaction by setting the corresponding inhibit input high, the note is returned immediately.

The sequence of operations is as follows:

- Pin 10 held low awaiting note insertion.
- Note inserted. Validator issues a 100 ms pulse on the appropriate channel.
- The host machine initiates vend process.
- The host machine sets pin 10 high to indicate that it wants the note. If this is not done within 30 seconds the Validator will return the note.
- The Validator issues a 100 ms pulse on the appropriate channel after pin 10 going high to indicate final acceptance of the note. If the signal has not been received within 30 seconds it indicates the customer has forcibly retrieved the note and the vend will be aborted.
- The vend process is completed.
- The host machine sets pin 10 low in expectation of the next vend.
- The host machine can force the return of the note to the customer by setting the inhibit line high, at any time before the end of the 30 second time-out. For channels above 4, setting all the inhibits high will cause a note reject.
- In the event of a note being forcibly removed from the mouth of the NV9 USB during the 30 second interval, the NV9 USB will go out of service for 45 seconds.

SSP ESCROW FUNCTION

To hold a note in the escrow position when using SSP, the POLL command should be replaced with the HOLD command after NOTE READ > 0 for as long as the note is to be held in escrow. A POLL command will then accept the note; the REJECT command will return the note to the customer



APPENDIX E - USB TO VALIDATOR CABLE ASSEMBLY – CN392

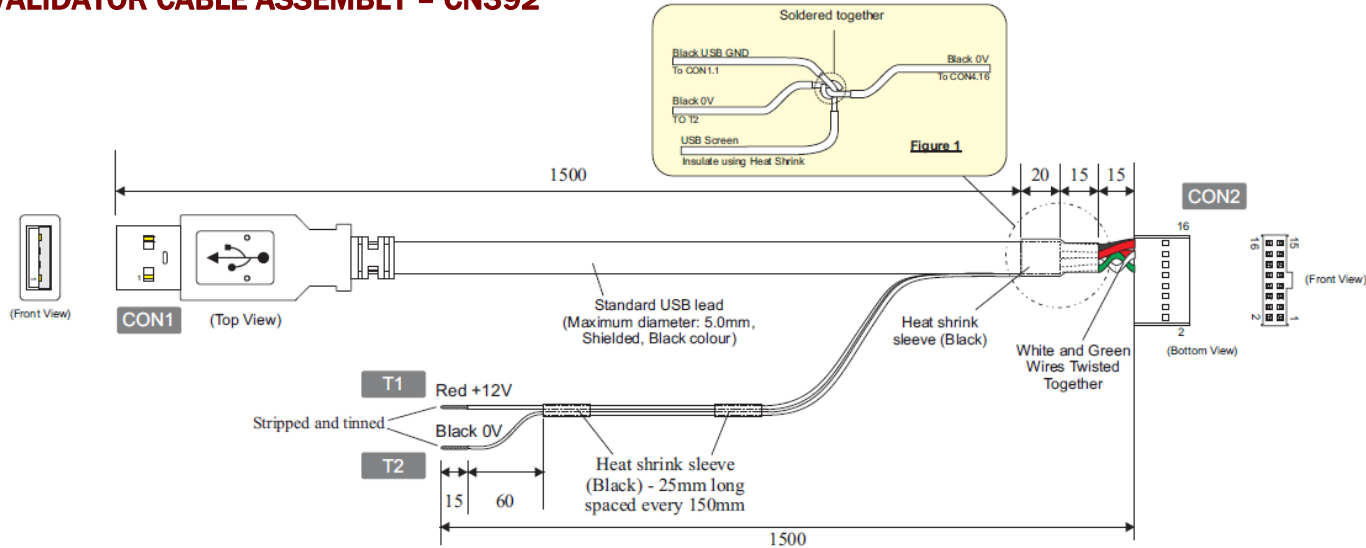

Terminal	Housing	Crimp	Comments
CON1	USB type A plug	-	CON1 connects to host machine
CON2	Molex 90142-0016 (2x8Way 2.54mm pitch with key)	9733272 (tin plated)	CON2 connects to validator

Connectivity by conductor					
CON1 Pin	CON2 Pin	Gauge	Colour	Comments	
1	13-	-	Red	V-Bus	
2	12	-	White	Data Minus (Twist together with Data Plus)	
3	11	-	Green	Data Plus (Twist together with Data Minus)	
4	16-	-	Black	USB GND Refer to Figure 1 for connection detail	
Screen	16	-	Black	Refer to Figure 1 for connection detail	
-	16	0.2mm ²	Black	0V, Cable rated to UL1007, Refer to Figure 1 for connection detail	
-	15	0.2mm ²	Red	+12V, Cable rated to UL1007, Refer to Figure 1 for connection detail	
-	1	-	-	Fit unloaded crimp terminal.	
-	2	-	-	Fit unloaded crimp terminal.	
-	3	-	-	Fit unloaded crimp terminal.	
-	4	-	-	Fit unloaded crimp terminal.	

Note: All other pins are unloaded.



APPENDIX F – BEZEL

**PA188BK - VERTICAL UP STACK
BLACK**



**PA191 - VERTICAL DOWN STACK
EXTENDED SNOOT BEZEL ASSEMBLY**



**PA189 - HORIZONTAL BEZEL
ASSEMBLY**



**PA189BK - HORIZONTAL BEZEL
ASSEMBLY (BLACK)**



**PA190 - VERTICAL UP STACK
EXTENDED SNOOT BEZEL ASSEMBLY**



**PA190BK - VERTICAL UP STACK EXTENDED
SNOOT BEZEL ASSEMBLY (BLACK)**



**PA268 - 69MM FIXED WIDTH
HORIZONTAL BEZEL**



**PA268BK - 69MM FIXED WIDTH
HORIZONTAL BEZEL (BLACK)**



PA256 - 66MM VERTICAL UP BEZEL



**PA296BK - VERTICAL UP/DOWN FLAT
66MM BEZEL ASSEMBLY (BLACK)**



**PA323 - VERTICAL UP/DOWN FLAT
69MM (ALSO AVAILABLE IN BLACK)**



**PA324 - VERTICAL UP/DOWN EXTENDED
66MM (ALSO AVAILABLE IN BLACK)**



APPENDIX G – CASH BOXES

PA185 - CLIP ON CASH BOX ASSEMBLY (300C)



PA186 - LOCKING CASH BOX ASSEMBLY (300L)



PA192 - SLIDE ON CASH BOX ASSEMBLY (300S)

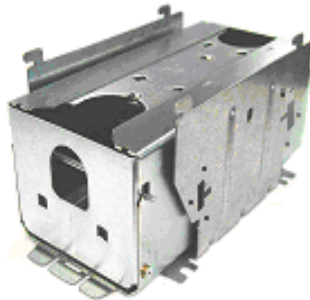

PA193 - CLIP ON CASH BOX ASSEMBLY (600C)



PA194 - SLIDE ON CASH BOX ASSEMBLY (600S)



INDEX OF TABLES

Table 1 - Environmental Requirements	5
Table 2 - Power Requirements	5
Table 3 - Interface Logic Levels	5
Table 4 - Available Interfaces/Protocols	6
Table 5 - Bezel LED Status Codes	7
Table 6 - 16 Pin Connector Details	8
Table 7 - Configuration Button Functions	9
Table 8 - eSSP Connection details	10
Table 9 - ccTalk connection details	12
Table 10 - Parallel Connection Details	15
Table 11 - SIO Connection Details	19
Table 12 - Serial Output Parallel Input Connection Details	20
Table 13 - NV9 USB Fault finding	26
Table 14 - Configuration Card Error Codes	31
Table 15 - NV9 USB program Check Bezel Codes	32

INDEX OF FIGURES

Figure 1 - The NV9 USB Validator	6
Figure 2 - Pin Detail	8
Figure 3 - SSP Configuration Card Options	11
Figure 4 - ccTalk pin connection diagram	12
Figure 5 - ccTalk Configuration Card Options	13
Figure 6 - MDB Configuration Card Options	14
Figure 7 - Parallel Configuration Card Options	16
Figure 8 - Pulse Configuration Card Options	18
Figure 9 - SIO Configuration Card Options	20
Figure 10 - Bezel and NV9 USB Installation	22
Figure 11 - Clip On and Slide in Cash Boxes	22
Figure 12 - NV9 USB Sensor Location	23
Figure 13 - Belt Access	24
Figure 14 - Belt Removal	25
Figure 15 - Escrow Timing Diagram for Parallel Vends	33



REVISION HISTORY

ITL			
TITLE	NV9 USB OPERATIONS MANUAL		
DRAWING NO	AUTHOR	DATE	FORMAT
GA450	SR	14/12/2009	MS Word 2000

ISSUE	RELEASE DATE	MODIFIED BY	COMMENTS
1	14/12/09	SR	First Issue



CONFIGURATION CARD

