



®

Innovative Technology

INTELLIGENCE IN VALIDATION



A.u.S. SPIELGERÄTE GMBH

SCHEYDGASSE 48, AT 1210 WIEN

+43 (0) 1 271 66 00 65 FAX +43 (0) 1 271 66 00 75

www.aus.at ✉ verkauf@aus.at

SMART Hopper

[GA00401]



USER MANUAL

User Manual SMART Hopper

[<< Back to Contents](#)

Document Name:	SMART Hopper
Document Version:	2.1
Date of Release:	07/08/2018

TABLE OF CONTENTS

1	DOCUMENT INTRODUCTION	4
1.1	RELATED DOCUMENTS	4
1.2	MANUAL AMENDMENTS.....	4
1.3	COPYRIGHT	4
1.4	LIMITED WARRANTY	4
1.5	PRODUCT SAFETY INFORMATION	5
2	PRODUCT INTRODUCTION	7
2.1	GENERAL DESCRIPTION.....	7
2.2	KEY FEATURES	7
2.3	TYPICAL APPLICATIONS.....	7
2.4	COMPONENT OVERVIEW	7
3	TECHNICAL DATA	8
3.1	DIMENSIONS	8
3.2	WEIGHT	8
3.3	ENVIRONMENTAL REQUIREMENTS	9
3.4	POWER REQUIREMENTS	9
3.4.1	Supply Voltages.....	9
3.4.2	Supply Currents.....	9
3.4.3	Power Supply Guidance	9
3.5	INTERFACE LOGIC LEVELS	9
3.6	RELIABILITY DATA.....	10
3.7	MEDIA REQUIREMENTS	10
4	MECHANICAL INSTALLATION	11
4.1	COMPATIBILITY	11
4.1.1	Hardware Compatibility.....	11
4.1.1.1	Machine Mounting	11
4.1.1.2	Machine Interfacing.....	11
4.1.1.3	Power Supply	11
4.1.2	Software Compatibility	12
4.1.2.1	Interface Protocols.....	12
4.1.2.2	Re-programming.....	12
4.2	NOZZLE MOUNTING	13
4.2.1	Nozzle Fitting	13
4.2.2	Nozzle Removal.....	14
4.3	BASEPLATE MOUNTING	14
4.3.1	Baseplate Fitting.....	14
4.3.2	Baseplate Removal	15
4.4	LOCK MOUNTING.....	16
4.4.1	Lock Fitting.....	16
4.4.2	Lock Removal.....	19
4.4.3	Lock Specifications	20
4.4.4	Lock Cam.....	21
4.5	MACHINE MOUNTING.....	22
4.5.1	Machine Mounting	22
4.5.2	Earth Bonding	23



User Manual SMART Hopper

[<< Back to Contents](#)

4.5.3	Screw Specifications.....	23
5	SOFTWARE INSTALLATION AND CONFIGURATION.....	24
5.1	INTRODUCTION.....	24
5.2	SOFTWARE DOWNLOADS.....	24
5.3	DRIVERS.....	24
5.4	DATASET/FIRMWARE PROGRAMMING.....	24
5.4.1	<i>Validator Manager</i>	24
5.4.1.1	General Description.....	24
5.4.1.2	System Requirements.....	24
5.4.1.3	Hardware Setup.....	25
5.4.1.4	Switching to Programming Mode (SSP).....	25
5.4.1.5	Programming the device.....	26
5.4.2	<i>Remote Updates</i>	27
5.4.2.1	General Description.....	27
5.4.2.2	Hardware Requirements.....	27
6	PROTOCOLS AND INTERFACING.....	28
6.1	INTRODUCTION.....	28
6.2	SSP AND ESSP.....	28
6.2.1	<i>General Description</i>	28
6.2.2	<i>Pin Assignments</i>	28
6.2.3	<i>Setup Examples</i>	31
6.2.3.1	SSP Setup – SMART Hopper Direct USB BENCH TESTING	31
6.2.3.2	SSP Setup – SMART Hopper with IF17.....	32
6.2.3.3	SSP Setup – SMART Hopper and TEBS.....	33
6.3	CC2.....	34
6.3.1	<i>General Description</i>	34
6.3.2	<i>Pin Assignments</i>	34
6.3.3	<i>ccTalk® DES Encryption</i>	36
6.3.4	<i>Setup Example Drawing/s</i>	36
7	ROUTINE MAINTENANCE.....	37
7.1	INTRODUCTION.....	37
7.2	RECOMMENDED CLEANING INTERVALS.....	37
8	FIRST LEVEL SUPPORT.....	38
8.1	BEZEL/STATUS LED FLASH CODES.....	38
8.2	STATUS LED FLASH CODES.....	38
9	SECOND LEVEL SUPPORT.....	39
9.1	INTRODUCTION.....	39
9.2	FAULT FINDING FLOW CHART.....	39
9.3	CLEARING A JAM.....	42
9.4	CHECKING POWER CONNECTIONS.....	44
9.5	CHECKING COMMUNICATION CONNECTIONS.....	44
9.6	CLEANING THE SMART HOPPER.....	45
9.7	TIMING CHECK.....	47
9.8	CHECKING PAY-OUT FLAP.....	48
10	COMPLIANCES AND APPROVALS.....	49
10.1	EC DECLARATION OF CONFORMITY.....	49
11	APPENDIX.....	50
11.1	CABLE DRAWINGS.....	50
11.2	LOCK SPECIFICATIONS.....	54
11.3	SWITCHING TO PROGRAMMING MODE (SSP).....	55
11.3.1	<i>Units Pre-Revision 30</i>	55
11.3.2	<i>Units from Revision 30</i>	56



User Manual SMART Hopper

[<< Back to Contents](#)

11.4	FREE FALL CASHBOX ADVICE.....	56
11.5	CC-TALK DES ENCRYPTION – TRUSTED MODE.....	57
11.6	CONFIGURATION BUTTON FUNCTIONS.....	57
11.7	FILE NAMING CONVENTION.....	57
11.8	ENERGY PROFILES.....	58
11.8.1	<i>Power up</i>	58
11.8.2	<i>Idle</i>	58
11.8.3	<i>Pay out</i>	59
11.8.4	<i>Empty</i>	59
11.8.5	<i>Coin Jam</i>	60



1 DOCUMENT INTRODUCTION

1.1 Related Documents

This document should be read together with the following:

For SSP/eSSP:

[Protocol Manual – SSP \(GA138\) : SSP Interface Protocol Specification for integration](#)

[SSP Implementation Guide \(GA973\) : Information for programmers and integrators](#)

For other third-party interface protocols contact support@innovative-technology.com.

1.2 Manual Amendments

Rev.	Date	Amendment Details	Issued by
2.0	18/05/2018	First Issue	J. Shaw
2.1	07/08/2018	Addition of coin mech socket information, SSP socket update	J. Shaw

1.3 Copyright

This manual set is copyright © Innovative Technology Ltd. 2018. No part of this publication may be reproduced in any form or by any means used to make any derivative such as translation, transformation, or adaptation without permission from Innovative Technology Ltd. The contents of this manual set may be subject to change without prior notice.

1.4 Limited Warranty

Innovative Technology Ltd warrants each of its hardware products to be free from defects in workmanship and materials under normal use and service for a period commencing on the date of purchase from Innovative Technology Ltd or its Authorized Reseller, and extending for the length of time stipulated by Innovative Technology Ltd.

A list of Innovative Technology Ltd offices can be found in every section of this manual set. If the product proves defective within the applicable warranty period, Innovative Technology Ltd will repair or replace the product. Innovative Technology Ltd shall have the sole discretion whether to repair or replace, and any replacement product supplied may be new or reconditioned.

The foregoing warranties and remedies are exclusive and are in lieu of all other warranties, expressed or implied, either in fact or by operation of law, statutory or otherwise, including warranties of merchantability and fitness for a particular purpose.

Innovative Technology Ltd shall not be liable under this warranty if it's testing and examination disclose that the alleged defect in the product does not exist or was caused by the customer's or any third person's misuse, neglect, improper installation or testing, unauthorized attempts to repair, or any other cause beyond the range of



[<< Back to Contents](#)

the intended use. In no event will Innovative Technology Ltd be liable for any damages, including loss of profits, cost of cover or other incidental, consequential or indirect damages arising out the installation, maintenance, use, performance, failure or interruption of an Innovative Technology Ltd product, however caused.

1.5 Product Safety Information

Throughout this user manual key safety points are raised for awareness when using or maintaining the product.

These safety points are highlighted in a box, like this:

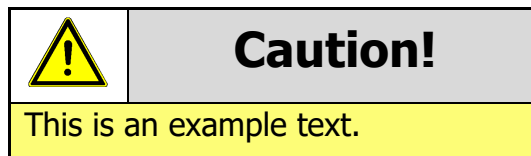

This user manual and the information it contains is only applicable to the model stated on the front cover, and must not be used with any other make or model.



Safety Notice! Read before using this product!

Safety Notice - Warning. Ensure power is removed before allowing access to the inside of this product. Ensure any static build up is discharged before allowing access to any part of this product or media contained. Always earth this product/base plate in accordance with the manual.

For use only in or with complete equipment where the acceptability of the combination is determined by UL LLC. When installed in an end-product, consideration must be given to the following:

- The power supply terminals and/or connectors are: Not investigated for field wiring
- The investigated Pollution Degree is: 2
- The following end-product enclosures are required: Mechanical, Fire

Sicherheitshinweis – Warnung: Es muss sichergestellt werden, dass das Gerät von der Versorgungsspannung getrennt wird, bevor ein Eingriff in das Innere des Gerätes erfolgt. Es muss sichergestellt werden, dass jegliche statische Aufladung des Gerätes entladen wird, bevor auf das Gerät oder auf innerhalb des Gerätes befindliche Objekte zugegriffen wird. Die Erdung des Gerätes muss immer gemäß Handbuch erfolgen.

Nur für die Verwendung in oder mit kompletter Ausstattung, dessen Eignung und Kombination von der UL LLC ermittelt wurde. Bei der Installation in einem Endprodukt, muss folgendes berücksichtigt werden:

- Die Spannungsversorgungsklemmen und/oder Verbinder sind: Feldverkabelung wurde nicht untersucht
- Der untersuchte Verschmutzungsgrad ist: 2
- Folgende Anforderungen an die Gehäuse des Endproduktes sind gefordert: Mechanisch, Feuer

Aviso de seguridad: Asegúrese de que la alimentación está desconectada y de que toda la energía estática es descargada antes de manipular este producto. Conecte a tierra la chapa base de la manera que se indica en el manual.

Solo para uso con dispositivos con los cuales la compatibilidad ha sido certificada por UL LLC. Tras su instalación en producto acabado, tener en cuenta lo siguiente:

- Los conectores y terminales de alimentación son: No se ha investigado/especificado cableado externo.
- El grado de contaminación determinado es: 2
- Los siguientes manuales/certificados de producto final son requeridos: Mecánico, Fuego

Avis de sécurité : Assurez-vous que l'alimentation est coupée et que toute l'énergie statique est déchargé avant de manipuler ce produit. Connecter à la terre, la plaque de base à la manière indiquée dans le manuel.

A utiliser Seulement avec les dispositifs dont la compatibilité a été certifiée par UL LLC. Après son installation dans le produit fini, prendre en considération ce qui suit:-

- Les connecteurs et les bornes d'alimentation sont : cela n'a pas été étudié/spécifié câblage externe.
- Le degré de contamination déterminé est: 2
- Les manuels suivants / les certificats du produit final sont nécessaires : mécanique, incendie

Bezpečnostní upozornění. Před manipulací uvnitř tohoto produktu se ujistěte, že je produkt odpojen od zdroje elektrického napětí. Ujistěte se, že jakýkoliv elektrostatický náboj byl vybit před manipulací s jakoukoliv částí tohoto produktu nebo obsaženým médiem. Vždy uzemněte tento produkt/základovou desku v souladu s návodem.

Pouze pro použití v nebo s kompletním vybavením, kde je přijatelnost kombinace určena UL LLC. Při instalaci v konečném produktu je třeba zvážit následující:

- Napájecí svorky a/nebo konektory: Nejsou sledované pro externí kabeláž
- Sledovaný stupeň znečištění je: 2
- Následující krytí konečného produktu jsou požadované: Mechanické, Protipožární



2 PRODUCT INTRODUCTION

2.1 General Description

The SMART Hopper from Innovative Technology is a state of the art multi-coin hopper and recycler that eliminates coin starvation. Boasting a market leading mixed coin capacity, the SMART Hopper removes the need for multiple hoppers, maximising cash efficiency.

The SMART Hopper reduces the cost of handling coins internally, eliminating the need for multiple hoppers & sorters. Operating at an industry leading 12 coins per second the SMART Hopper is a true multi-coin pay-out unit capable of accepting all coins passed through the coin mechanism.

2.2 Key Features

- State of the art multi coin hopper & recycler
- Technologically advanced
- Lowest cost of ownership
- High security

2.3 Typical Applications

- Gaming
- Amusement
- Vending
- Retail & Kiosk

2.4 Component Overview

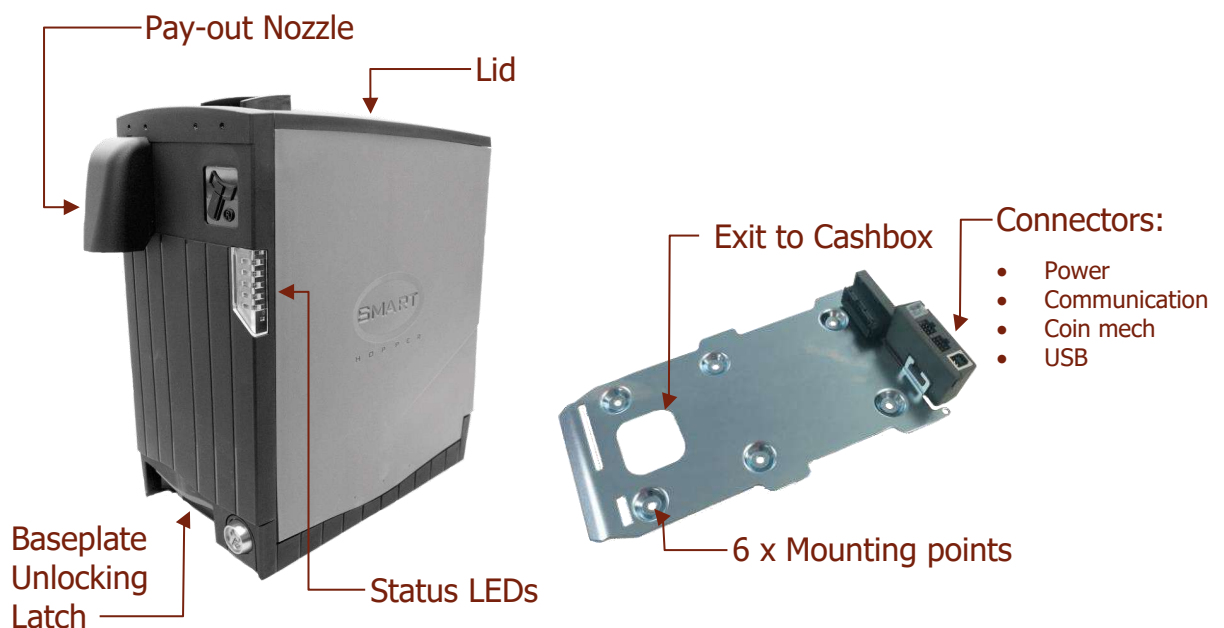

User Manual SMART Hopper

[<< Back to Contents](#)

3 TECHNICAL DATA

3.1 Dimensions

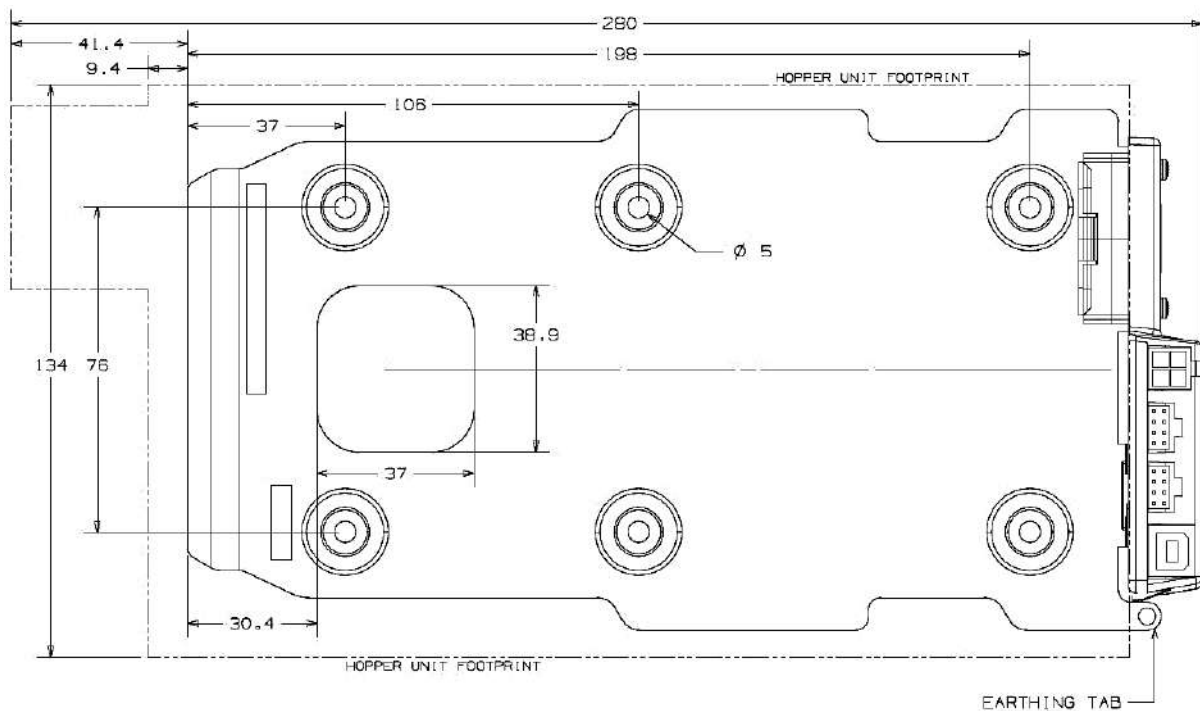
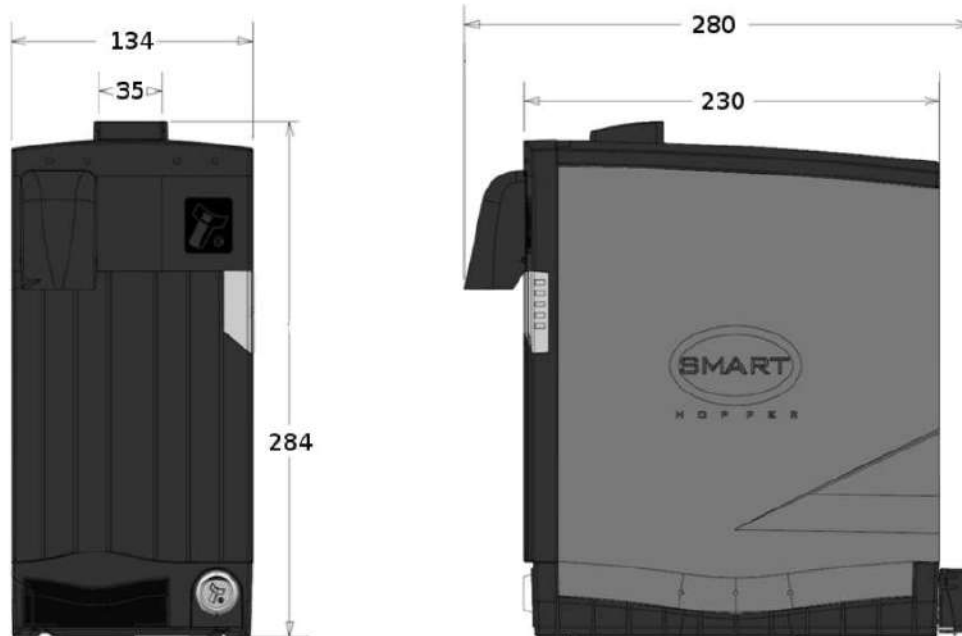

3.2 Weight

Part	Empty	Full
SMART Hopper and Baseplate	2.75kg	12.26kg
SMART Hopper	2.5kg	12kg
Baseplate	0.26kg	N/A



User Manual SMART Hopper

[<< Back to Contents](#)

3.3 Environmental Requirements

Environment	Minimum	Maximum
Temperature	+3°C	+50
Humidity	5%	95% Non-condensing

3.4 Power Requirements

3.4.1 Supply Voltages

Supply Voltage	Minimum	Nominal	Maximum
Supply Voltage (V DC)	+ 21.6 V DC	+ 24 V DC	+ 26.4 DC
Supply Ripple Voltage	0 V	0 V	0.25 V @ 100 Hz

3.4.2 Supply Currents

The supply current required to run the SMART Hopper will vary during the phases of operation. Below is a table detailing the required current.

Supply Current	Current Draw (A)
Standby	0.2 A
Running	3.0 A
Peak	6.5 A

3.4.3 Power Supply Guidance

The SMART Hopper requires a stable 24 V DC / 6.5 A power supply. Check the power requirements of the host machine and other peripherals to spec a suitable power environment for the machine setup.

TDK Lambda manufactures suitable power supplies. See the table below for further details.

Power Supply Unit	Specification	RS Stock Code	Farnell Stock Code
TDK Lambda SWS300-24	+24 V DC / 13.0 A	494-4651	1085928

3.5 Interface Logic Levels

Interface Logic Levels	Logic Low	Logic High
Inputs	0V to +0.5V	+3.7V to +12V
Outputs with 2K2Ω pull-up resistor	+0.6V	Pull-up voltage of host interface
Maximum Current Sink	50mA per Output	



[<< Back to Contents](#)

3.6 Reliability Data

- MCBF
200,000
- MCBI
50,000

3.7 Media Requirements

Coin	Minimum	Maximum
Diameter	18mm	28.5mm
Thickness	1.6mm	3.2mm

Depending on the currency a different SMART Hopper Hardware type is required. Contact support@innovative-technology.com for further information. Detailed information is available on request.



4 MECHANICAL INSTALLATION

4.1 Compatibility

4.1.1 Hardware Compatibility

4.1.1.1 Machine Mounting

Assuming the suitable base plate type has been ordered the SMART Hopper can be used as a fitting replacement for competitor coin hopper solutions.

Innovative Technology Ltd. has a policy of continuous product improvement. Due to design changes older model or product pay-nozzles may not be compatible with the SMART Hopper.

	Caution!
Only use pay-out nozzle (and baseplate) delivered with the product!	

4.1.1.2 Machine Interfacing

The SMART Hopper may need changes to existing machine harnessing.

4.1.1.3 Power Supply

It is critical that the SMART Hopper is connected to a power supply being able to provide the required power at the correct specification. A weak power supply will cause the SMART Hopper to malfunction like coin rejects or missing credits. If the SMART Hopper is used as a fitting replacement for an older model or product it is recommended to check the power supply specifications of the machine. The power supply of the machine might be designed for the older model or product but not suitable for the SMART Hopper. The SMART Hopper might have higher power consumption. Refer to [3.4 Power Requirements](#) for full power requirement details of the SMART Hopper.

	Caution!
A weak power supply causes malfunctioning!	

4.1.2 Software Compatibility

4.1.2.1 Interface Protocols

When using the SMART Hopper as a fitting replacement for an older model or product some events such as credits may be given incorrectly. This is due to improved firmware routines and faster motors being used. This may cause missing events such as credits in those host machines where timeouts are defined for the older model or product. Contact the machine manufacturer for full compatibility of the SMART Hopper.

	Caution!
Timing issues may cause missing events such as credits!	

4.1.2.2 Re-programming

For re-programming the SMART Hopper always use the latest version of Validator Manager available for download on ITLs website. Older versions may not support the SMART Hopper. For further details on Re-programming the SMART Hopper refer to [5.4.1.5 Programming the device](#)

	Caution!
Older versions of Validator Manager may not support the SMART Hopper!	

User Manual SMART Hopper

[<< Back to Contents](#)

4.2 Nozzle Mounting

4.2.1 Nozzle Fitting

1. Alignment

Position the pay-out nozzle in line with the cut outs for the nozzle.



2. First latch

Attach the top clip in to the front of the SMART Hopper



3. Final attachment

Now place the side clips in to the corresponding holes and push until they click in to place



User Manual SMART Hopper

[<< Back to Contents](#)

4.2.2 Nozzle Removal

1. Side clips

Pull the low section of the pay-out nozzle until the 2 side clips release.



2. Top Clip

Pivoting the nozzle up will unhook the top clip.



4.3 Baseplate Mounting

4.3.1 Baseplate Fitting

1. Baseplate Fitting

Slide the SMART Hopper on to the baseplate until it engages the latch with a click.



4.3.2 Baseplate Removal

1. Latch

Press the latch on the front of the SMART Hopper up.



2. Pull

With the latch still pressed pull the SMART Hopper forward.

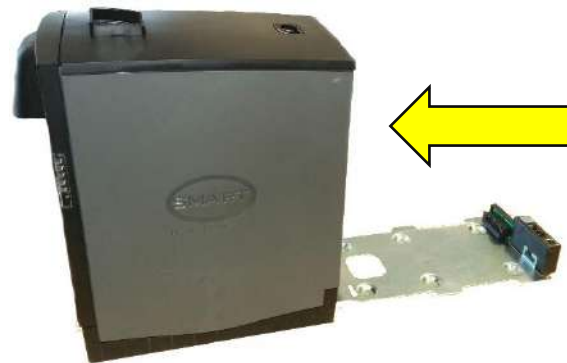

User Manual SMART Hopper

[<< Back to Contents](#)

4.4 Lock Mounting

4.4.1 Lock Fitting

1. Latch

Press the latch on the front of the SMART Hopper up.



2. Pull

With the latch still pressed pull the SMART Hopper forward.



3. Blanking Plate

The blanking plate is located on the front of the SMART Hopper lower right.



4. Screws

Remove the 2 screws and remove the blanking plate and lock holder.



User Manual SMART Hopper

[<< Back to Contents](#)

5. Disassembly Lock holder

Remove blanking plate from the lock holder. Push on the outer edges of the blanking plate and push through the hole.

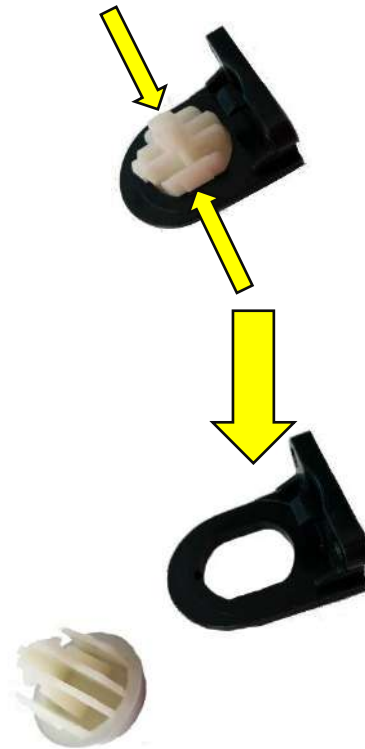

6. Barrel Lock Disassembly

Remove the 2 nuts and direction cam from the lock.

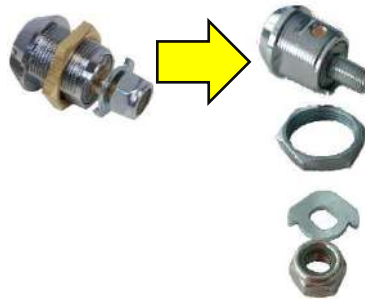

7. Assembly

1. Place the barrel lock in to the lock holder.
2. Attach barrel lock fixing nut.
3. Place the direction cam over the rear of the barrel lock.



Caution!

Special care should be taken with the direction cam if positioned wrong it will change the direction the lock opens.

4. Place MC00211 on the barrel lock.
5. Tighten the nylon locking nut on to the barrel lock.



8. Attaching Lock Assembly

The lock assembly will need to be rotated in to place. Once in place use the 2 screws to fix the lock assembly in place.

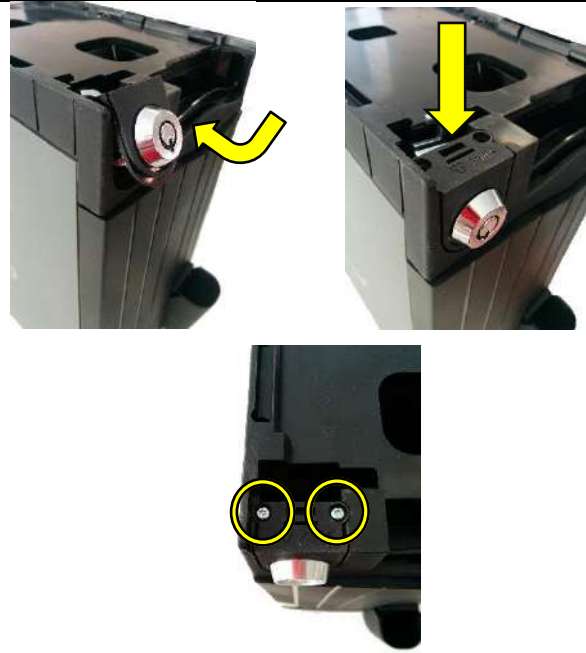

User Manual SMART Hopper

[<< Back to Contents](#)

4.4.2 Lock Removal

1. Latch

Press the latch on the front of the SMART Hopper up.



2. Pull

With the latch still pressed pull the SMART Hopper forward.

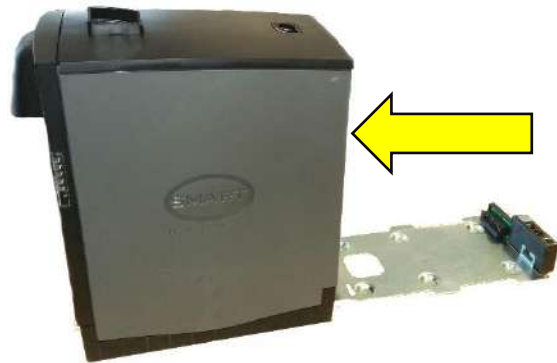

3. Blanking Plate

The blanking plate is located on the front of the SMART Hopper lower right.



4. Screws

Remove the 2 screws and remove the barrel lock assembly.



User Manual SMART Hopper

[<< Back to Contents](#)

5. Description 1

1. Unfasten the nylon locking nut.
2. Remove MC00211 cam.
3. Remove the direction cam from the rear of the barrel lock.
4. Unfasten the nut fixing the barrel lock to the lock holder.
5. Remove the barrel lock from the holder.



6. Description 2

Clip the lock blank in to the lock holder.



7. Description 3

Replace the lock blank and holder in the SMART Hopper and refasten the 2 screws.



4.4.3 Lock Specifications

Locks for the SMART Hopper are available from Innovative Technology Ltd.

Part Number: 9930100414 PA02540

Webshop Link: [Round Key Lock KD PA02540](#)

However, there are various lock manufacturers and distributors. Refer to [11.2 Lock Specifications](#) for lock specification.



4.4.4 Lock Cam

The following Lock Cam needs to be ordered additionally to the lock for full locking capability.

Part Number: 9930100438 [SMART Hopper 4 - MC00211](#)



User Manual SMART Hopper

[<< Back to Contents](#)

4.5 Machine Mounting

4.5.1 Machine Mounting

1. **Bolt holes for fixing baseplate to surface.**
6 x Bolt holes highlighted

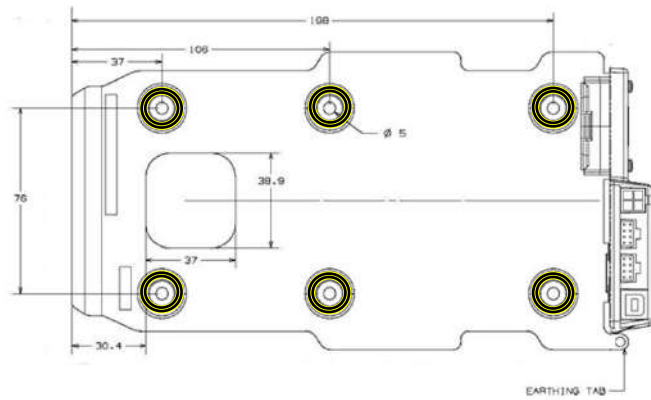

2. **Earthing Tab**
1 x Earthing tab.

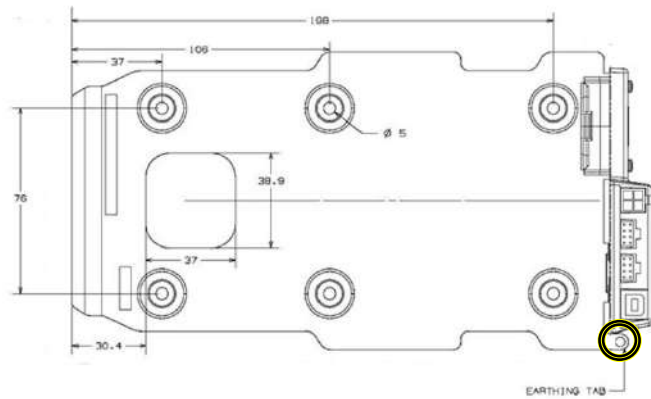

3. **Cashbox Entry Hole**
1 x Cashbox entry hole

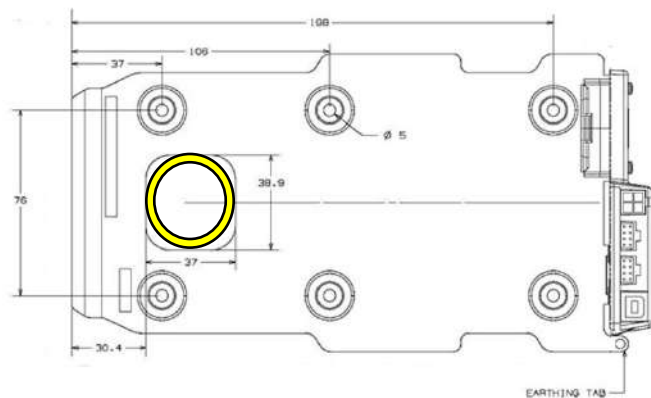

4.5.2 Earth Bonding

It is very important that the SMART Hopper is properly bonded to earth as described in [4.5.1 Machine Mounting](#). Lack of proper bonding can cause communication issues and other failures.

	Caution!
Lack of proper earth bonding causes failures!	

4.5.3 Screw Specifications

The SMART Hopper does not include screws for machine mounting. See table below for screw specification reference.

Type	Head Diameter		Head Height		Bolt Diameter		Bolt Length	
	Min	Max	Min	Max	Min	Max	Min	Max
Pan Head	8mm	11mm	2mm	4mm	N/A	M4	10mm	N/A



5 SOFTWARE INSTALLATION AND CONFIGURATION

5.1 Introduction

The SMART Hopper leaves the factory pre-programmed with the latest dataset and firmware files. However, it is important to ensure the device is kept up to date with the latest dataset and firmware. This section will give a brief overview of the various update possibilities with the SMART Hopper. For detailed instructions refer to the relevant manual package supplied with the software or contact support@innovative-technology.com.

5.2 Software Downloads

All software from Innovative Technology Ltd is free of charge and can be downloaded from the www.innovative-technology.com/support/secure-download once registered and logged in. If an account isn't made, create an account via the Create an account form. A confirmation email will be sent to the registered email address once all contact details have been successfully submitted.

5.3 Drivers

The ITL drivers allow connection to any of ITLs validators to a compatible Windows device. If connecting via an IF17 then this process doesn't need to be followed as they are signed Microsoft Drivers and should install automatically. If this isn't the case or the computer is disconnected from the network, there is a standalone package included within the driver downloads available at www.innovative-technology.com/support/secure-download.

5.4 Dataset/Firmware Programming

5.4.1 Validator Manager

5.4.1.1 General Description

Validator Manager is a utility which allows the user to reprogram any of ITL's validators, hoppers as well as coin and note recycler. Note that admin rights are required during installation. The validator must be in SSP for Validator Manager to detect the device.

5.4.1.2 System Requirements

- Windows XP SP3 or above
- .Net Framework 4
- 256mb ram
- 50mb hard disk free
- Connected SMART Hopper with active com port

	Caution!
There have been instances where one of the dll's (itdata1.dll) used in Validator Manager are flagged as a Trojan, this is a false positive and if this happens add a rule to the antivirus to allow the file to run.	



User Manual SMART Hopper

[<< Back to Contents](#)

5.4.1.3 Hardware Setup

Connect the power supply to the IF17. Connect the USB cable to the IF17 and to the computer or laptop.

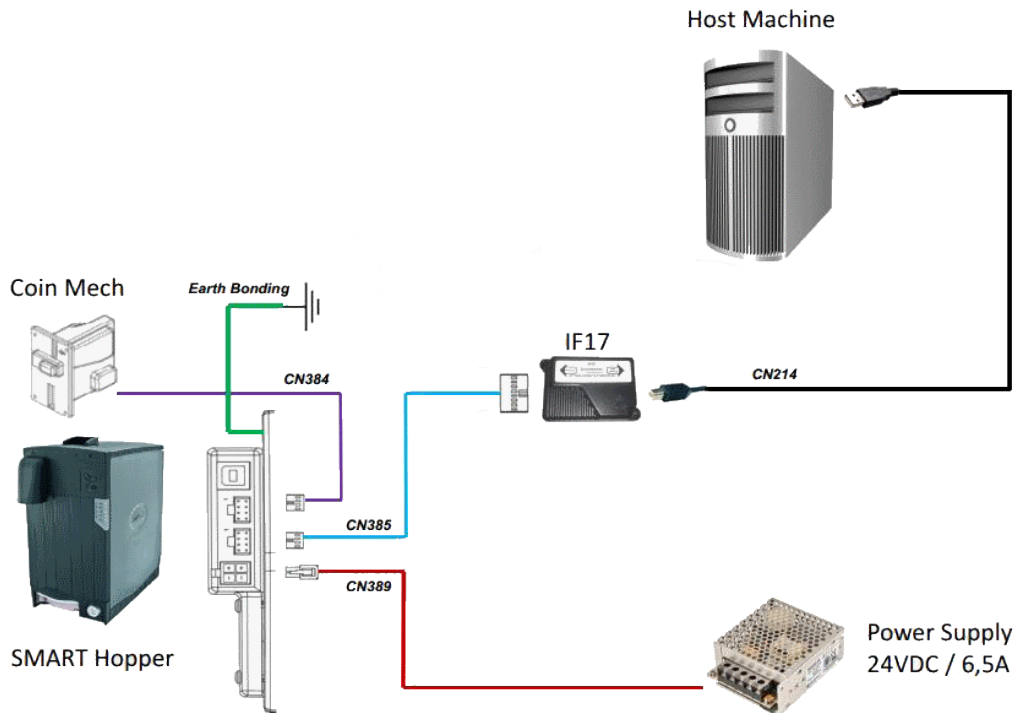

5.4.1.4 Switching to Programming Mode (SSP)

Before programming via Validator Manager the SMART Hopper needs to be switched to the SSP protocol (sometimes referred to as Programming Mode). Refer to [11.3 Switching to Programming mode](#) for the procedure on how to do this.



User Manual SMART Hopper

[<< Back to Contents](#)

5.4.1.5 Programming the device

Once the unit is switched into SSP, open Validator Manager and click detect devices. This will scan all active com ports for a unit, if the SMART Hopper fails to connect ensure the correct drivers are installed and the unit is in SSP. Refer to [11.3 Switching to Programming mode](#) for the procedure for doing this.

By selecting the Program tab, the SMART Hopper can be reprogrammed. To begin the upload, click open file, then browse to the file location (usually Downloads) before clicking OK.

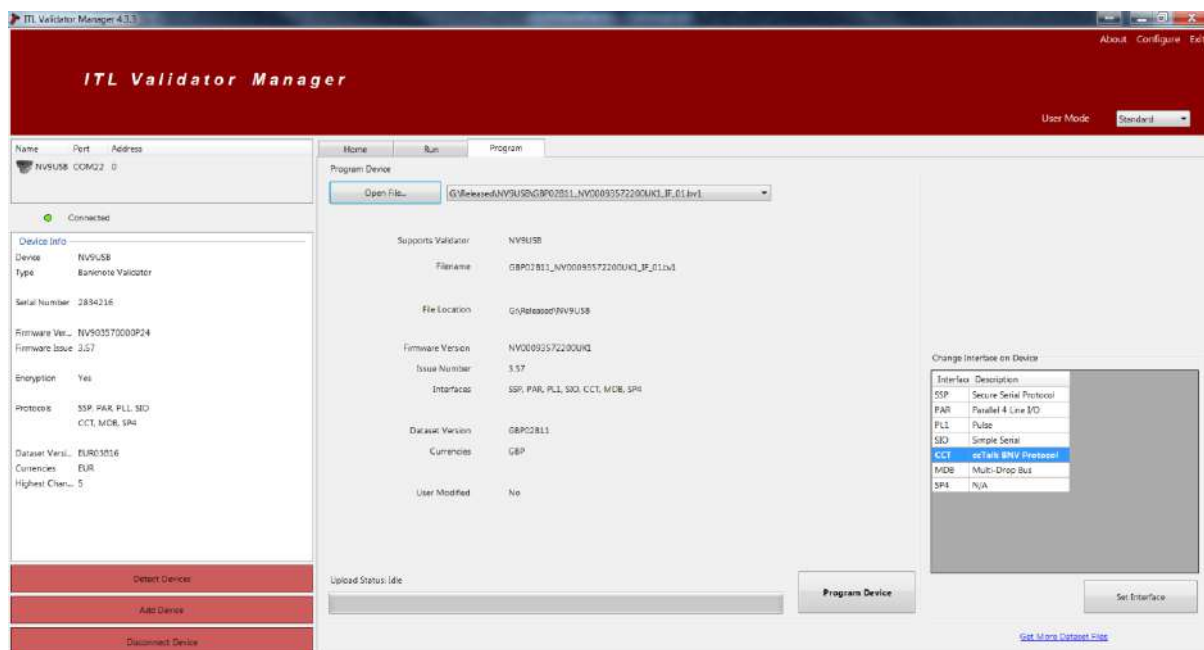

Once the file has been selected its information will be populated and the Program device tab will become active. Finally hit 'Program Device', the unit's status LEDs will now begin to flash signaling the update has begun.

	<h2>Caution!</h2>
<p>Interrupting the download process can result in the unit entering a non-functional state, once the process has started it cannot be halted.</p>	

When completed the unit will restart and a pop-up box will appear saying Device Programming Complete.



5.4.2 Remote Updates

5.4.2.1 General Description

As part of Innovative Technology Ltd continued development and improvement, periodically new dataset and/or firmware for validators is released. This could be for improved acceptance, additional features or security updates. Network connected cabinets and applications communicating in SSP can the functionality to update the devices attached through the application software. DLLs and libraries are available to assist with this development. Contact the local support office with requirements for more assistance. This section outlines the software processes involved in updating a validator with a new dataset/firmware file. Implementation of this process allows a validator to be updated from a remote location using the host machine software.

5.4.2.2 Hardware Requirements

Connect the power supply to the IF17. Connect the USB cable to the IF17 and to the computer or laptop.

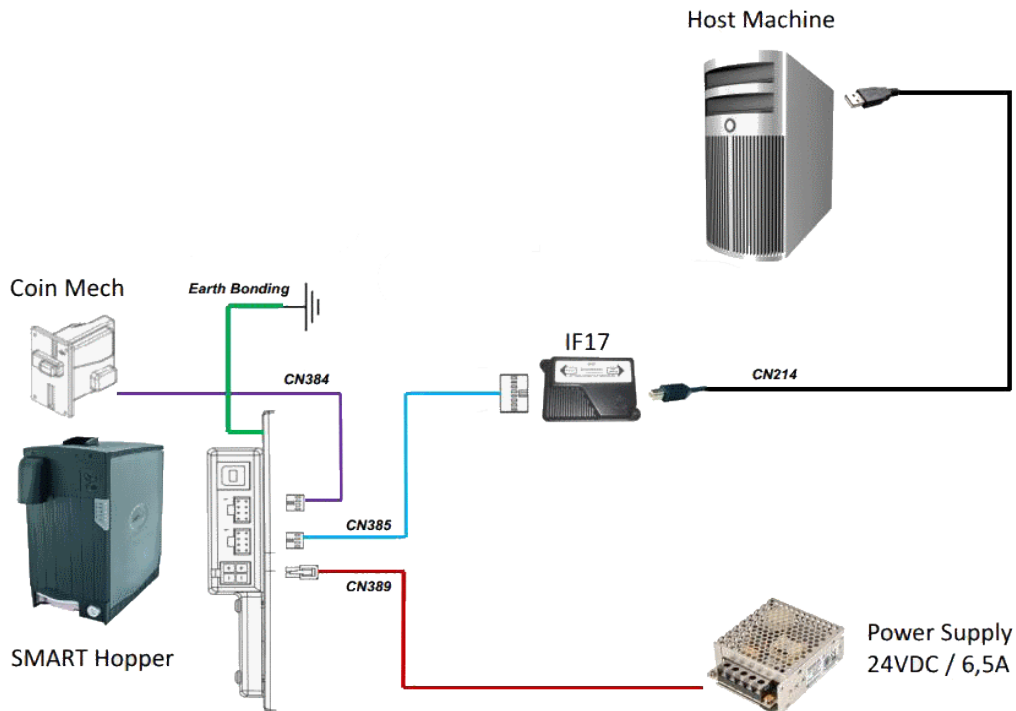

6 PROTOCOLS AND INTERFACING

6.1 Introduction

The SMART Hopper supports standard industry protocols. Interfaces that are not listed may be available upon request. For any queries regarding interfaces that are not listed contact support@innovative-technology.com.

	Caution!
The use of an encrypted protocol (preferable eSSP) is strongly recommended to achieve the highest security!	

6.2 SSP and eSSP

6.2.1 General Description

Smiley® Secure Protocol (SSP) and Encrypted Smiley® Secure Protocol (eSSP) are field proven secure interfaces specifically designed by Innovative Technology Ltd. to address the problems with cash handling systems in gaming machines. Problems such as acceptor swapping, re-programming acceptors and line tapping are all addressed. This interface is recommended for all new developments. Innovative Technology Ltd. provides full SDK packages upon request including Interface Specification, Implementation Guide as well as source code examples for C++, C#.NET and Linux. Contact support@innovative-technology.com for further information.

6.2.2 Pin Assignments

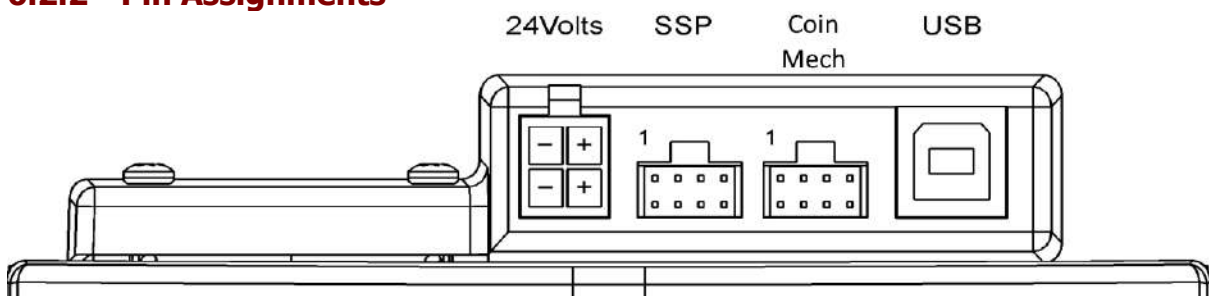

	Caution!
+24VDC and 0V (GND) must always be connected, even when using USB connections.	

User Manual SMART Hopper

[<< Back to Contents](#)

The first connector is a 4 pin socket used to power up the SMART Hopper.

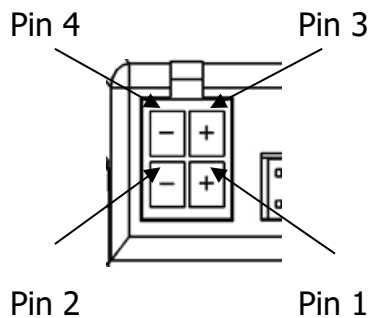

Pin	Description
1	V+ Power
2	0V / Ground
3	V+ Power (connected to Pin 1)
4	0V / Ground (connected to Pin 2)

Interface communication from the SMART Hopper unit to the host machine can communicate via SSP or CC2.

The SSP pin numbering of the socket is shown below, as well as an overview of the socket connections:

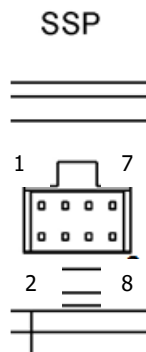

Pin	Description
2	Ground
7	Serial Data Out (Tx)
8	Serial Data In (Rx)

The Coin mech pin numbering of the socket is shown below, as well as an overview of the socket connections:

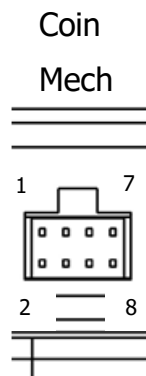

Pin	Description
1	V+ Power
2	Ground
7	Serial Data (CCT RX)



User Manual SMART Hopper

[<< Back to Contents](#)

The USB connector is a standard Type B USB socket. The USB socket can be used for programming the SMART Hopper unit and bench testing – a USB 2.0 compliant Type 'A' to 'B' lead can be used to do this. USB cables should be electrically shielded and less than 5 metres long.

USB

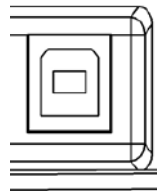

Caution!

Direct USB should **NOT** be used for Host communications. If USB is required then an IF17 (TTL to USB) should be used.



User Manual SMART Hopper

[<< Back to Contents](#)

6.2.3 Setup Examples

The drawings below highlight how to connect the SMART Hopper to an SSP host machine using available cables and interfaces from Innovative Technology Ltd. For cable drawings refer to [11. 1 Cable Drawings](#)

6.2.3.1 SSP Setup – SMART Hopper Direct USB **BENCH TESTING**

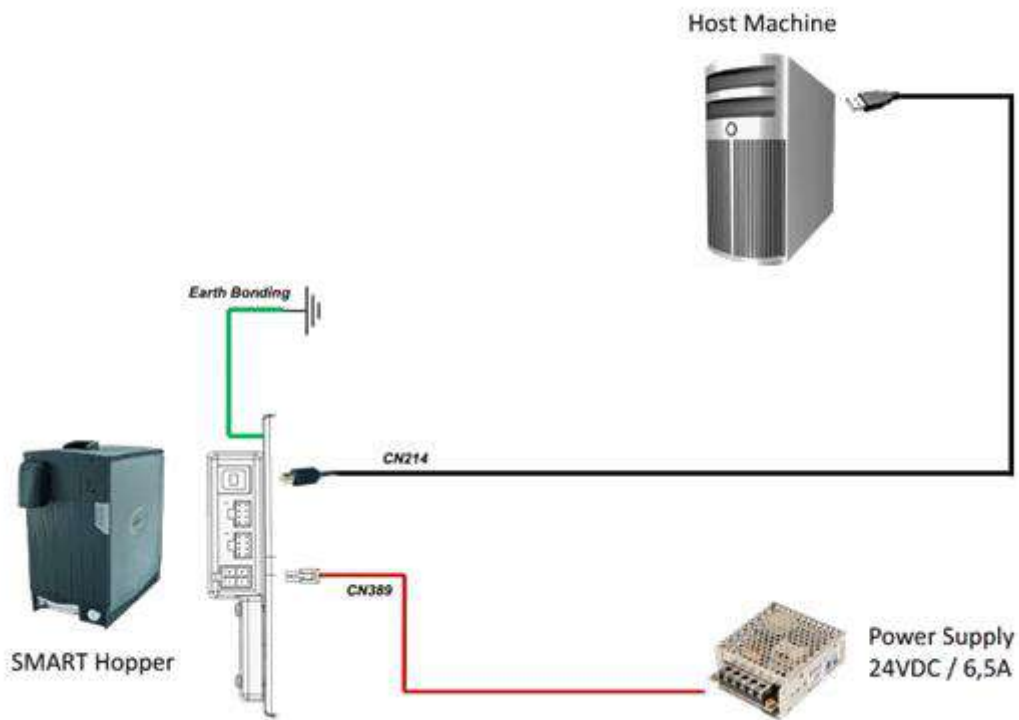

Type	ITL Part Number	Description	Details
Cable	CN00214	USB Type A to B	USB Type A to B
Cable	CN00389	Smart Hopper Power Cable	Smart Hopper Power Cable

	Caution!
Direct USB should NOT be used for Host communications. If USB is required then an IF17 (TTL to USB) should be used.	



User Manual SMART Hopper

[<< Back to Contents](#)

6.2.3.2 SSP Setup – SMART Hopper with IF17

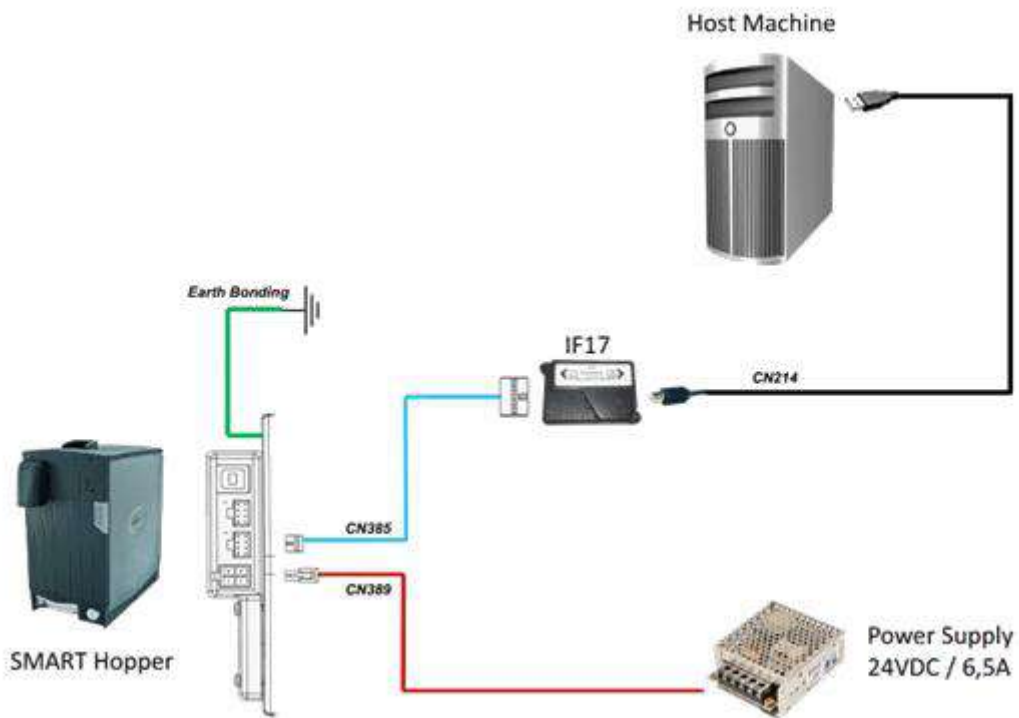

Type	ITL Part Number	Description	Details
Cable	CN00385	SMART Hopper to IF17 Cable	SMART Hopper to IF17 Cable
Cable	CN00389	Smart Hopper Power Cable	Smart Hopper Power Cable
Cable	CN00214	USB Type A to B	USB Type A to B
Interface	IF17	TTL to USB Converter	TTL to USB Converter



User Manual SMART Hopper

[<< Back to Contents](#)

6.2.3.3 SSP Setup – SMART Hopper and TEBS

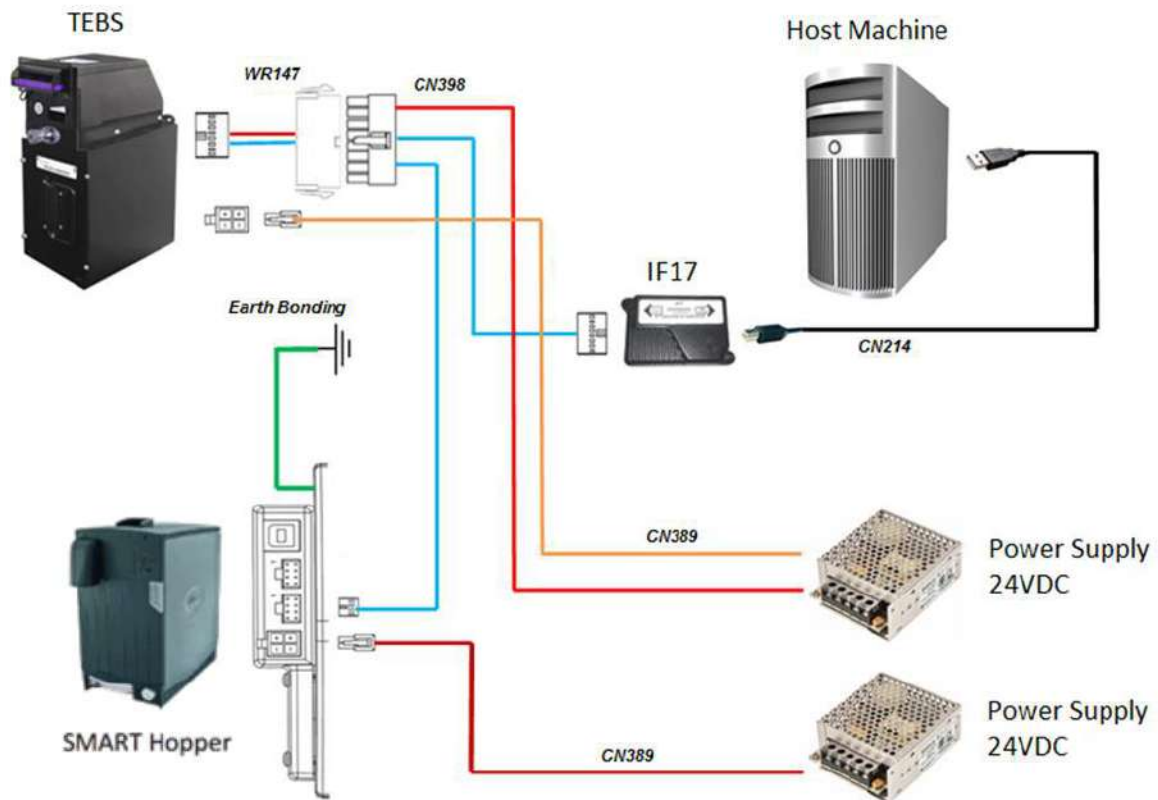

Type	ITL Part Number	Description	Details
Cable	CN00398	Dual eSSP interface for SMART Hopper & SMART Payout	Dual eSSP interface SMART & Payout
Cable	WR00147	SMART Payout To NV200 Adaptor	SMART Payout To NV200 Adaptor
Cable	CN00389	Smart Hopper Power Cable	Smart Hopper Power Cable
Cable	CN00214	USB Type A to B	USB Type A to B
Interface	IF17	TTL to USB Converter	TTL to USB Converter



User Manual SMART Hopper

[<< Back to Contents](#)

6.3 CC2

6.3.1 General Description

CC2 was designed by Innovative Technology Ltd. to reduce the development time and effort when implementing the SMART Coin System in software environments with existing ccTalk® infrastructures, without resigning any features and functionality. CC2 provides SSP features and functionality in a ccTalk® packet format. Contact support@innovative-technology.com for CC2 Interface Specification.

	Caution!
Innovative Technology Ltd. provides full SDK packages including Interface Specification, Implementation Guide as well as source code examples for SSP respectively eSSP only!	

6.3.2 Pin Assignments

	Caution!
The Pin Layout is identically to the SSP Layout. Depending on the Host System a link may be needed on the Rx and Tx line to establish communication.	

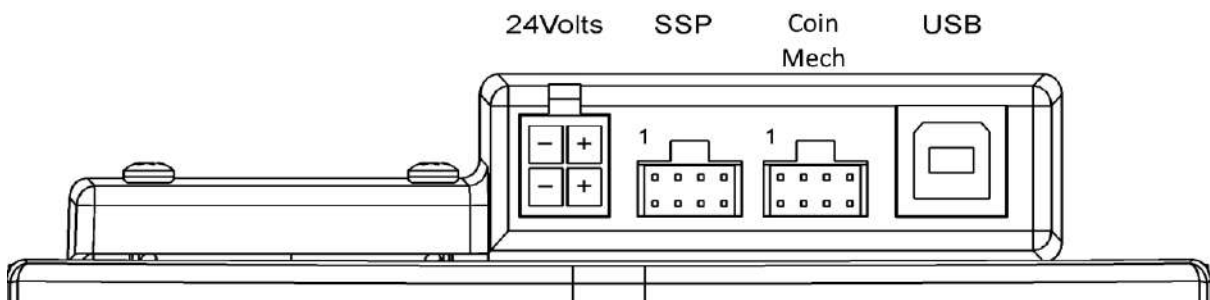

	Caution!
+24VDC and 0V (GND) must always be connected before using USB connections.	



User Manual SMART Hopper

[<< Back to Contents](#)

The first connector is a 4 pin socket used to power the SMART Hopper.

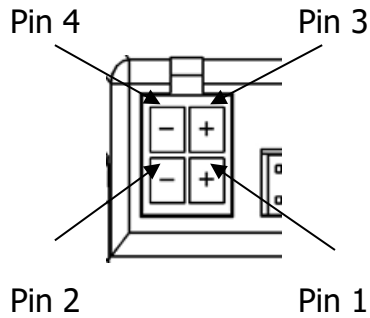

Pin	Description
1	V+ Power
2	0V / Ground
3	V+ Power (connected to Pin 1)
4	0V / Ground (connected to Pin 2)

Interface communication from the SMART Hopper unit to the host machine can communicate via SSP or CC2.

The SSP pin numbering of the socket is shown below, as well as an overview of the socket connections:

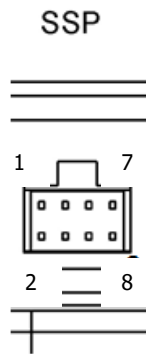

Pin	Description
2	Ground
7	Serial Data Out (Tx)
8	Serial Data In (Rx)

The Coin mech pin numbering of the socket is shown below, as well as an overview of the socket connections:

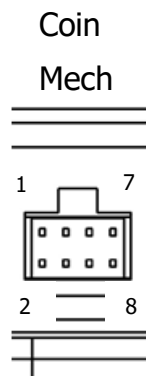



Pin	Description
1	V+ Power
2	Ground
7	Serial Data (CCT)

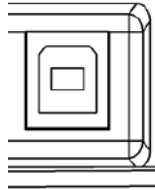

The USB connector is a standard Type B USB socket. The USB socket can be used for programming the SMART Hopper unit and bench testing – a USB 2.0 compliant Type 'A' to 'B' lead can be used to do this. USB cables should be electrically shielded and less than 5 metres long.

USB



	Caution!
Direct USB should NOT be used for Host communications. If USB is required then an IF17 (TTL to USB) should be used.	

6.3.3 ccTalk® DES Encryption

When using ccTalk® DES encryption, the SMART Hopper and host machine must exchange a secret key which forms the basis of the communication encryption. This exchange is performed in a Trusted Mode maintaining security. The Trusted Mode can only be entered by a physical access to the SMART Hopper. Refer to [11.5 ccTalk DES Encryption – Trusted Mode](#) for details.

6.3.4 Setup Example Drawing/s

Refer to the SSP setup example drawing in [6.2.3 Setup Examples](#). Depending on the host system a link between the Rx and Tx line may be needed to establish communication.

7 ROUTINE MAINTENANCE

7.1 Introduction

The SMART Hopper has been designed to minimise any performance variation over time. Much of this is achieved by careful hardware and software design. However, depending upon the environment the SMART Hopper may at some time require cleaning, belt changing or note path clearing.

7.2 Recommended Cleaning Intervals

Innovative Technology Ltd recommends cleaning the optical lenses every month or as required. Dirt, dust or other residue leads to bad coin acceptance and other performance degradation. Refer to [9.6 Cleaning the SMART Hopper](#)9.6 for comprehensive cleaning instructions.



8 FIRST LEVEL SUPPORT

8.1 Bezel/Status LED Flash Codes



8.2 Status LED Flash Codes

Status Indicators		Status	Indicated Status / Error
Red	Green		
●		1	Hopper disabled
		2	Calibration fault
		3	No encryption key set
		4	Coin jam
		5	Fraud attempt detected
		6	Hopper empty
		7	Memory Checksum error
		8	Hopper sensors are not initialised
		9	Exit Sensor 2 (6.25+) Lid Removed (legacy)
		10	Missing Opto Slot Detection
	●	Flashing (1Hz)	Enabled

9 SECOND LEVEL SUPPORT

9.1 Introduction

This section contains the essential information that the field engineer needs to clean, maintain and fault find a SMART Hopper that is installed in a host machine.

9.2 Fault Finding Flow Chart

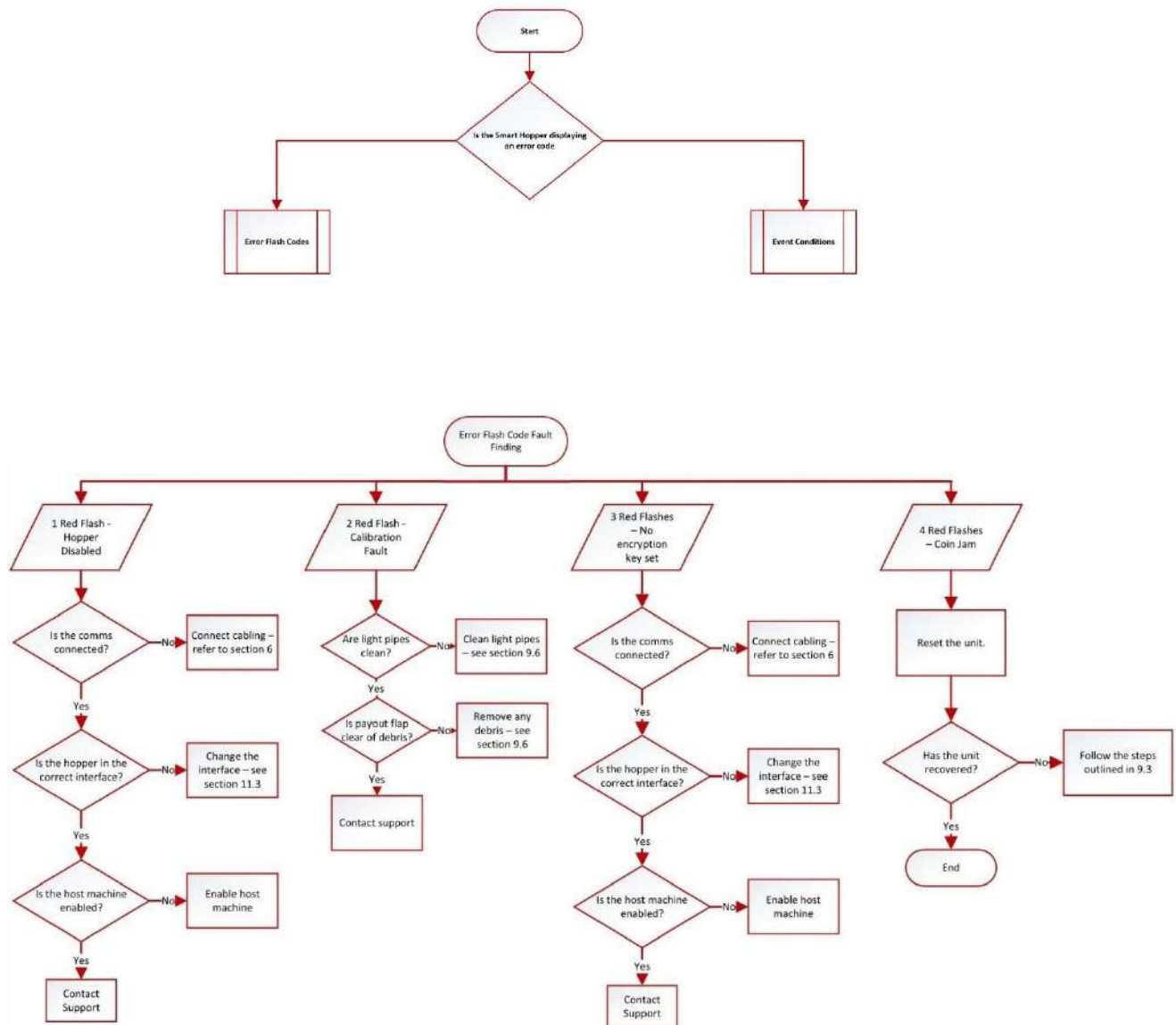

User Manual SMART Hopper

[<< Back to Contents](#)

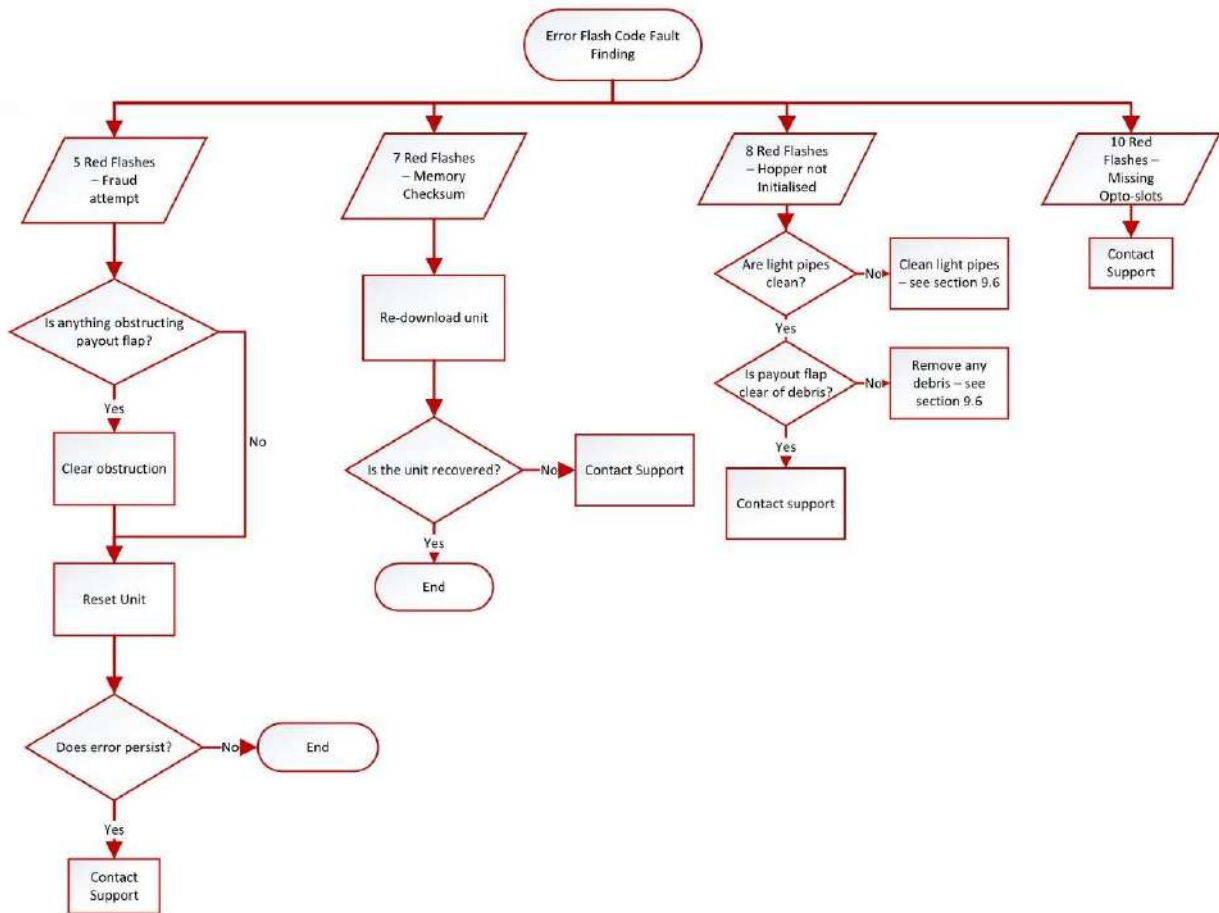

User Manual SMART Hopper

[<< Back to Contents](#)

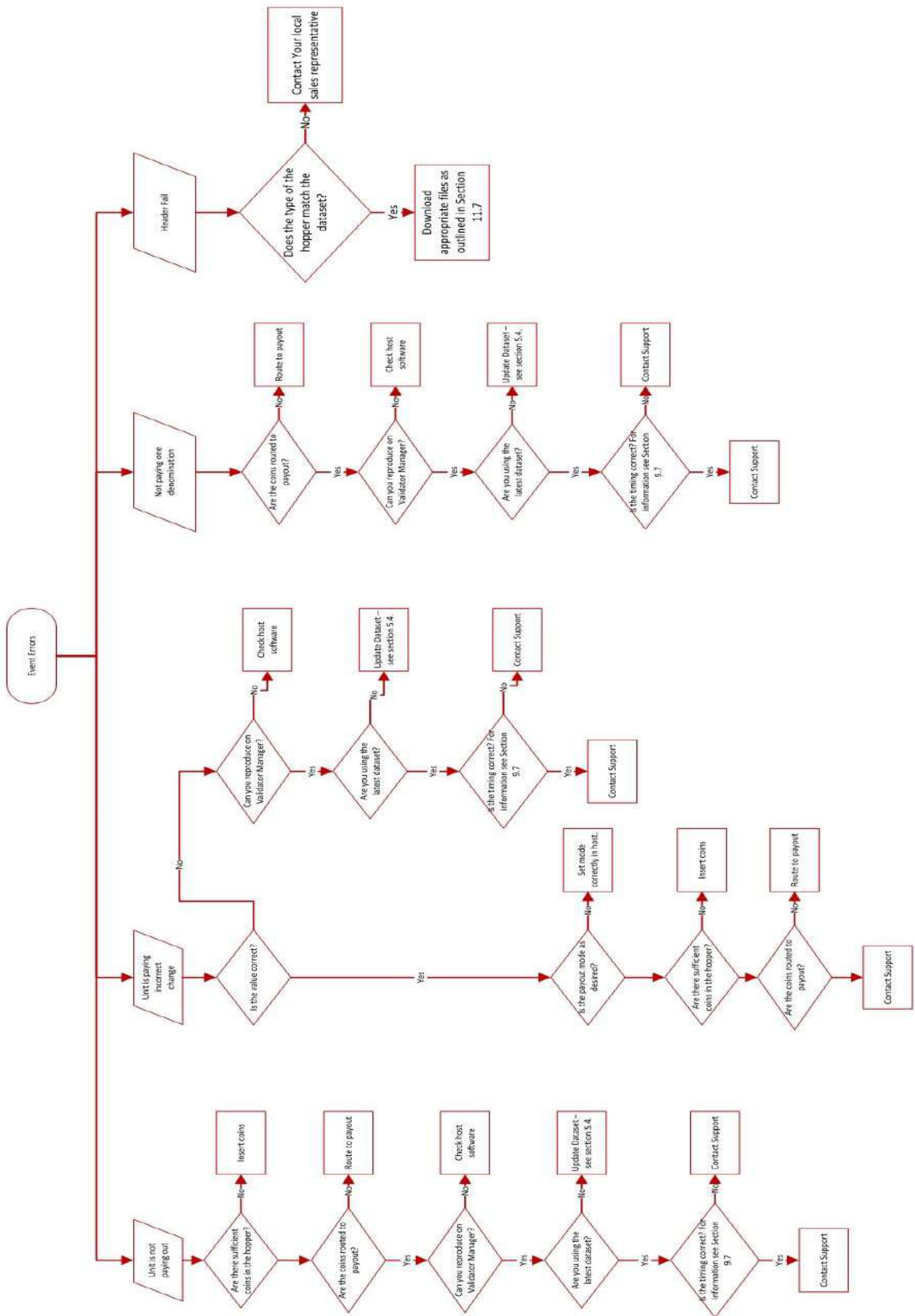

9.3 Clearing a Jam

1. Base Plate Removal

Press the latch on the front of the SMART Hopper to release it from the baseplate as described in [4.3 Baseplate Mounting](#)



2. Remove Lid

Press the latch on the lid and slide it back to remove the lid.



3. Empty the Coin Bowl

Empty all the coins from the SMART Hopper.



4. Clear the Jam

Turn the disk anti-clockwise to clear the jam.



5. Belt Clearing

While continuing to turn the disk collect the coins that will exit at the top of the conveyor belt.



6. Finished

Once the jam is clear replace the coins and lid. Then re-attach the baseplate.

9.4 Checking Power Connections

1. Power Cable

Check if the power cable is correctly fitted.

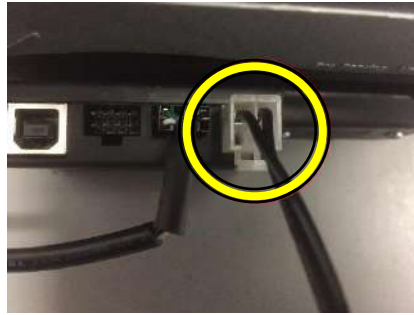

2. Power Specification

Check if the power supply meets the specification in section [4.1.1.3. Power Supply](#).

9.5 Checking Communication Connections

1. Communication Cable

Check if the communication cable is correctly fitted.



2. Interface Specification

Check if the communication cable and the machine setup meets the desired interface specification from section [6 Protocols and Interfacing](#)

9.6 Cleaning the SMART Hopper

1. Base Plate Removal

Press the latch on the front of the SMART Hopper to release it from the baseplate as described in [4.3 Baseplate Mounting](#)



2. Lid Removal

Press the latch on the lid and slide it back to remove the lid.



3. Nozzle Removal

Remove nozzle as described in [4.2 Nozzle Mounting](#)



4. Remove the Front Panel

From the top pull down and right (twist) the panel and the panel clips off.



5. Cleaning Light Pipes & Sensors

Clean the light pipes in the middle of the coin exit. With access to the PCB area it is now also possible to clean the sensor area.

The light pipes need cleaning frequently.

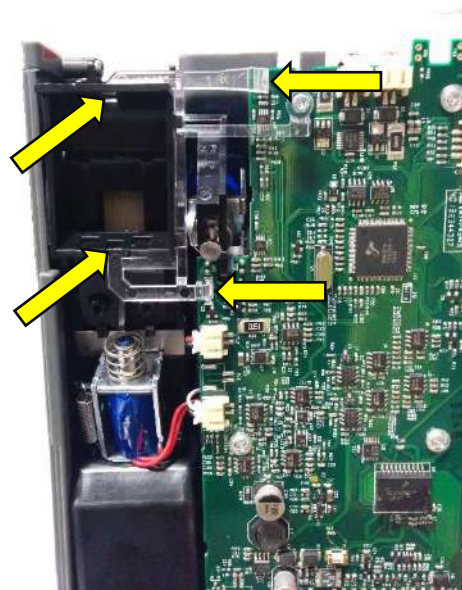

6. Cleaning Solenoid Actuators

Remove the solenoid actuators to clean them.

The solenoid actuators need to be cleaned occasionally.

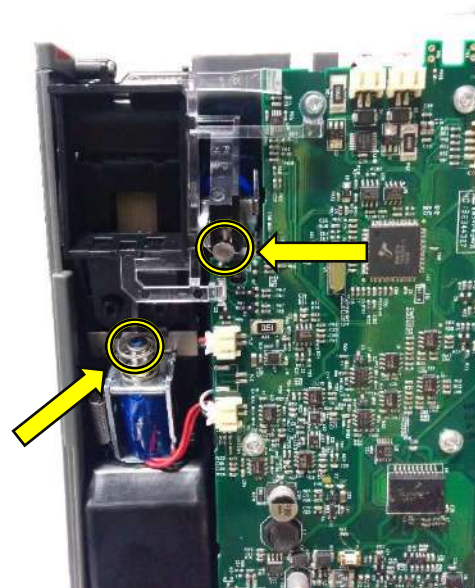

9.7 Timing Check

1. Base Plate Removal

Press the latch on the front of the SMART Hopper to release it from the baseplate as described in [Baseplate Mounting](#)



2. Lid Removal

Press the latch on the lid and slide it back to remove the lid.



3. Check Timing

Turn the disk until the tooth on the belt is about disappear under the plastic. The disk should be aligned with the rear panel.



9.8 Checking Pay-out Flap

1. Pay-out chute Removal

Remove pay-out chute as described in [4.2.2 Nozzle Removal](#)



2. Check Flap

Push and release the flap. The flap should move freely and spring back in to the closed position.



Caution!

Do not use solvent based cleaners such as alcohol, petrol, methylated spirits, white spirit or PCB cleaner. This will result in permanent damage to the SMART Hopper, only use a mild detergent.



Caution!

Dirt, dust or other residue causes bad note acceptance rates and other performance degradation. The recommended cleaning interval is once a month!

10 COMPLIANCES AND APPROVALS

10.1 EC Declaration of Conformity

- RoHS
- EN Directives
- UL
- REACH
- WEEE

Contact support@innovative-technology.com for further information. Detailed information is available on request.



User Manual SMART Hopper

[<< Back to Contents](#)

11 APPENDIX

11.1 Cable Drawings

All parts can be purchased as part of the ITL development kit, details of which can be found on ITLs website. [Development Kit Link](#)

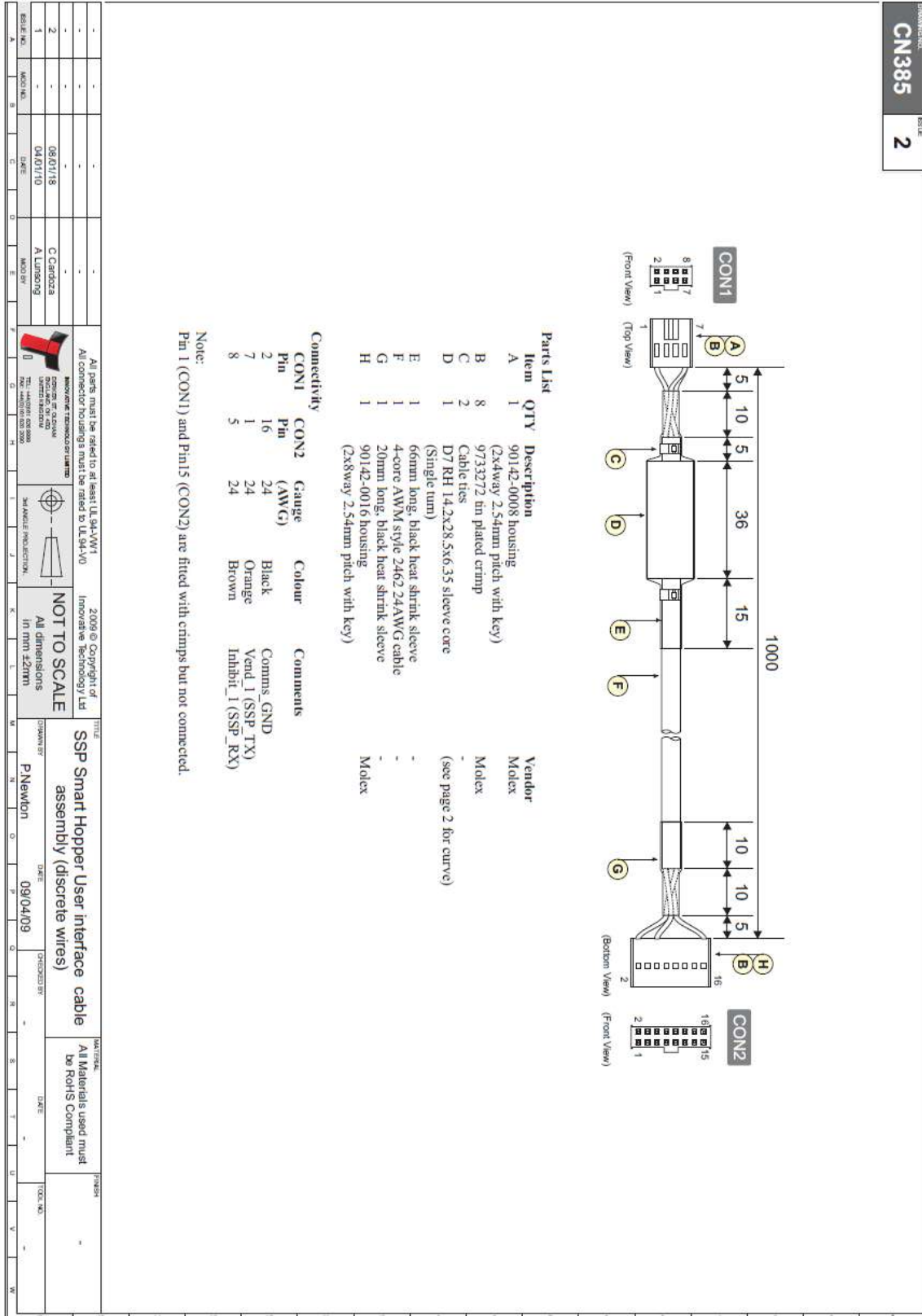

User Manual SMART Hopper

[<< Back to Contents](#)

DRAWING NO. **CN398** SIDE **1**

Parts List

Item	QTY	Description	Vendor	Connectivity	Gauge	Colour	Comments
A	1	0039012165 housing (2x8way 4.2mm pitch Mini-Fit receptacle)	Molex	CON1 Pin 1-16	24	Orange	SSP TX (Vend1)
B	4	0039000038 tin plated, female crimp 10-13-165082160-0 (K5A T16 5x8 2x16 toroidal core)	Molex	CON1 Pin 1-4	24	Brown	SSP RX (Inhibit1)
C	1	(2 turns (1 loop); cable tie to secure in place)	Padelford Electronics/ Z-Shen Enterprise	CON1 Pin 9	22	Red	V IN (12V)
D	10	15mm long, black heat shrink sleeve (spread along the length of harness with typical separation of 82mm) Standard 22AWG wire	-	CON1 Pin 2	24/22	Black	GND
E	2	553-0100-01 stackable black 4mm banana plug	Deltron	CON1 Pin 1 & 16	-	-	-
F	1	553-0500-01 stackable red 4mm banana plug	Deltron	CON1 Pin 7	-	-	-
G	1	4-core AWM style 2462 24AWG cable	-	CON2 Pin 1-4	-	-	-
H	2	25mm long, black heat shrink sleeve	-	CON2 Pin 5	-	-	-
I	4	90142-0008 housing (2x4way 2.54mm pitch with key)	Molex	CON3 Pin 1-4	-	-	-
J	1	9733272 tin plated crimp	Molex	CON3 Pin 1	-	-	-
K	8	90142-0016 housing (2x8way 2.54mm pitch with key)	Molex	CON4 Pin 1-8	-	-	-
L	1		Molex	CON5 Pin 1-16	-	-	-

Comments

CON1 mates with 6745-2160 straight header (on Smart Payout)
 CON2 connects to SSP Hopper Interface Port
 CON3 connects to V- (GND) of power supply
 CON4 connects to V+ (12V) of power supply
 CON5 connects to Host Machine

Note:
 Pin 14 and 16 (CON1) each has two wires crimped together.
 Pin 1 (CON1) has three wires crimped together. If crimp is unable to hold three wires together please use AWG 26 for the 4-core PVC cable.
 Pin 1 (CON2) is fitted with crimp but not connected.
 Pin 15 (CON5) is fitted with crimp but not connected.
 All other pins are unloaded.
 For the unused wire in the 4-core PVC cable, please trim excess or, if possible, please use a 3-core PVC cable.
 Length for both PVC cable is the same

Host machine (via CONS) connects both Hopper and Payout through different SSP addresses. Hence, SSP_TXD_(Vend1) on Payout and SSP_TX on Hopper are both linked to pin 1 (Vend1) on CONS.

REV	DATE	BY	CHKD	APPD	REASON
1	15/09/09	A Lunsong			

TITLE: **Dual eSSP interface to both Smart Payout and Hopper assembly**
 DRAWN BY: **A Lunsong** DATE: 15/09/09
 CHECKED BY: DATE:
 APPROVED BY: DATE:

All parts must be rated to at least UL94V-0
 All connector housings must be rated to UL94V-0
 Innovative Technology Ltd
 2009 © Copyright of
 NOT TO SCALE
 All dimensions
 in mm ±0.1mm



User Manual SMART Hopper

[<< Back to Contents](#)

CONNECTOR		SIZE	
CN389		4	

Parts List

Item	QTY	Description	Part Number	Vendor
A	1	4mm Stackable Plug, Red	553-0500-01	Deltron
B	1	4mm Stackable Plug, Black	553-0100-01	Deltron
C	1	Polarised Audio Wire, 2 x 0.5mm ² AWG 20-18	1586019-4	Tyco (TE Connectivity)
D	1	4 Circuit Receptacle Housing, 4.2mm PE Series UL94V-0	1586315-1	Tyco (TE Connectivity)
E	2	4.2mm PE Series Crimp Socket (Not Shown)		

Connectivity

CON1	CON2	CON3	Colour	Comments
Pin	Pin	Pin		
1	-	1	Red	24V (Hopper Power)
-	1	2	Black	0V (Hopper GND)

Note:
All other pin locations are empty.
Audio wire colour is not important but polarisation marking is required.

REV	A	-	12/01/2018	E Fill	All connector housings to be UL94 V-0 rated. All wire and heatshrink to be UL1581 VW-1 rated.	2009© Copyright of Innovative Technology Ltd	TITLE	Hopper Interface Power Cable	DRAWN BY	P. Newton	DATE	14/05/2009	CHECKED BY	-	MATERIAL	All Materials used must be RoHS Compliant	FINISH	-
REV	B	-	08/11/2017	E. Fill														
REV	C	ECN00469	28/02/2011	Placeholder														
REV	D	-	04/01/10	Placeholder														
REV	E	W02186	03/05	W02186														



User Manual SMART Hopper

[<< Back to Contents](#)

The following cable is available separately.

DRAWING NO. **CN496** SIZE **0a**

Terminal

Terminal	Housing	Crimp
CON1	Molex 90142-0008 (2x4way 2.54mm pitch with key)	9733272 (tin plated)
CON2	JST XHP-4 Connector Housing, 4 Way	BXH-001T-P0.6 28-22AWG

Connectivity by conductor

CON1 Pin	CON2 Pin	Gauge (AWG)	Colour	Comments
1	24	24	Red	+12VDC
2	3	24	Black	GND
7	4	24	Orange	Data (CCT_TX)

Comments
CON1 is connected to the Hopper base plate in the slot that says 'Coin Mech'.

Note: Pins not named are unloaded

All parts must be rated to at least UL 94-VW1
All connector housings must be rated to UL 94-V0

MANUFACTURED BY: INNOVATIVE TECHNOLOGY LIMITED
GENERAL OFFICE: 10000 INNOVATION DRIVE, WILLOWDALE, ONTARIO, CANADA
TEL: 416-709-1000 FAX: 416-709-1000

2009 © Copyright of Innovative Technology Ltd
NOT TO SCALE / All dimensions in mm ±2mm

DRAWN BY: P Newlon DATE: 20/04/2012 CHECKED BY: DATE: TITLE: Hopper to RM5 Coin Mech Cable Assembly

MATERIALS: All Materials used must be RoHS Compliant

FINISH: -



User Manual SMART Hopper

[« Back to Contents](#)

11.2 Lock Specifications

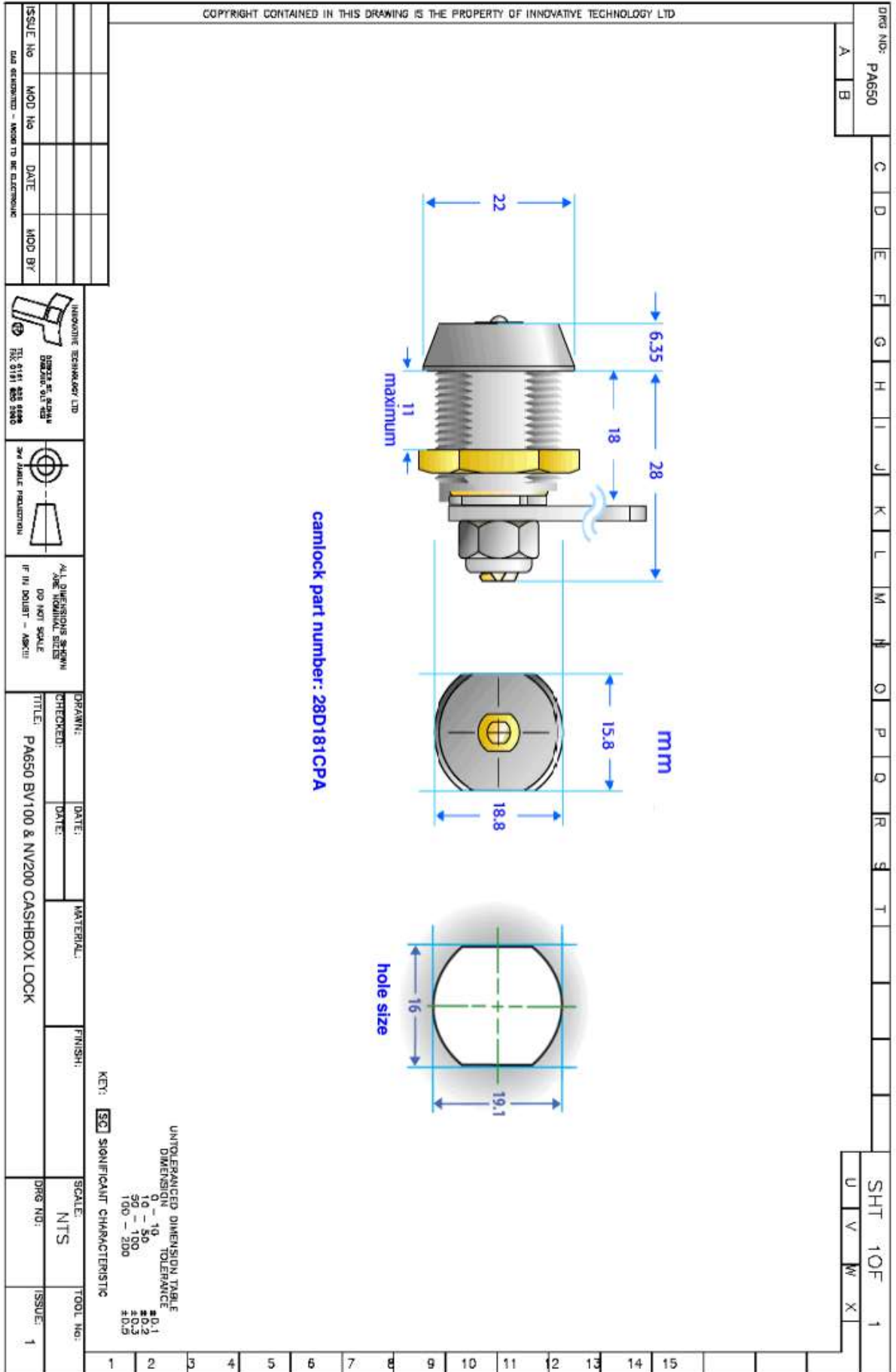

User Manual SMART Hopper

[<< Back to Contents](#)

11.3 Switching to Programming Mode (SSP)

11.3.1 Units Pre-Revision 30

Units before revision 30 can only use ITL software to change the Interface.

ccTalk Pay In & Pay-out System (**CPIPS**) software is required and is available from ITLs website software downloads section.

Connect the SMART Hopper as seen in [SSP Setup – SMART Hopper with IF17](#) run CPIPS.

1. CPIPS

Run CPIPS application then select Start-up. CPIPS will scan available communication ports for ccTalk devices and connect automatically.

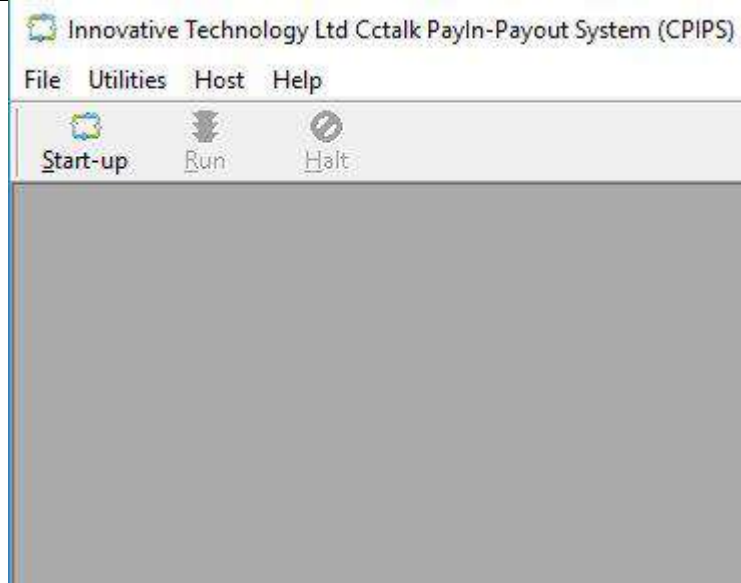

2. Menus

Once connected select the Utilities tab from the top followed by Set Device Interface. Then double click the SMART Hopper device option.

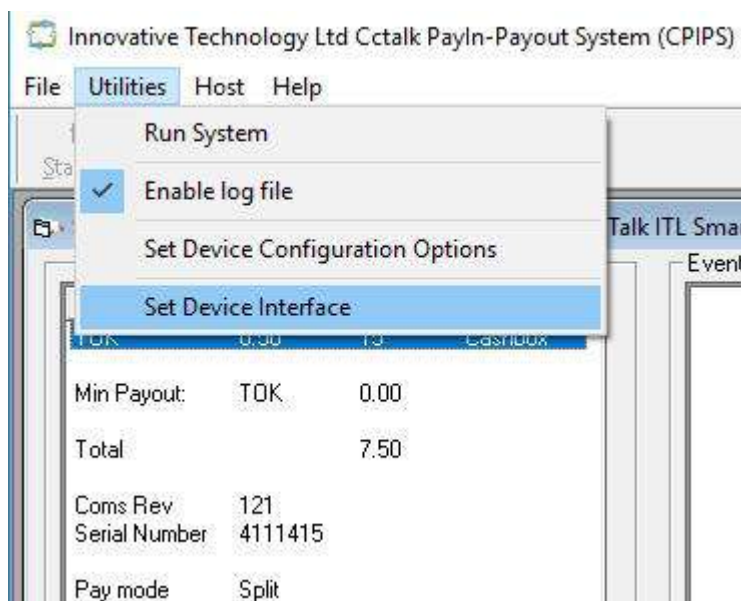

3. Setting Interface

Double click SSP to select eSSp Interface. The SMART Hopper will now reset and be available to use in Validator Manager for reprogramming, updating and running.

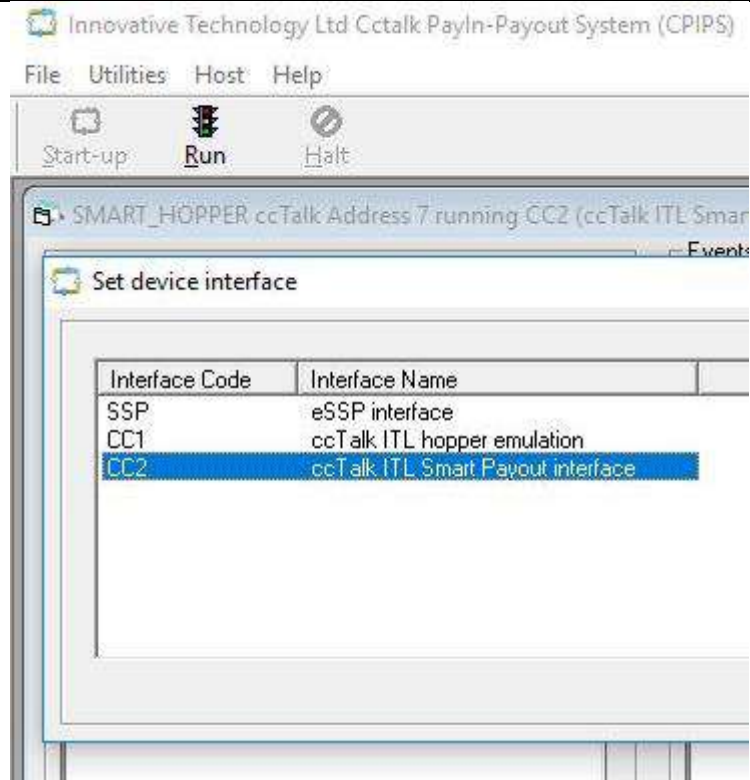

11.3.2 Units from Revision 30

Unit from Revision 30 onwards can use the button on the front of the SMART Hopper to change to programming mode refer to [11.6 Switching to Programming Mode \(SSP\)](#).

11.4 Free Fall Cashbox Advice

Ensure that there is space below the **exit chute** to allow the coins to fall clear of the coin exit.

	Caution!
Failure to keep the cashbox coin exit free from obstacles can result in coin jams and or damage the SMART Hopper.	

User Manual SMART Hopper

[<< Back to Contents](#)

11.5 ccTalk DES Encryption – Trusted Mode

When set to CC2 with DES enabled. DES trusted mode can be entered by resetting all denomination levels to 0. On a power cycle the SMART Hopper will automatically enter DES trusted mode for 2 minutes to allow for pairing to the host. The easiest way to set all levels to zero is to run an empty cycle.

11.6 Configuration Button Functions

From Revision 30 of the hopper a configuration button has been added to the front of the SMART Hopper.

Action	Power Status	Function
Press the button, then press the button again within 5 seconds (do not double click a pause of 2 sec in press is required)	Powered ON	Cycles interface between SSP, CC2 & CC1.
Press and hold for longer than 5 seconds	Powered ON	Switch between USB mode (CDE & HID)

11.7 File Naming Convention

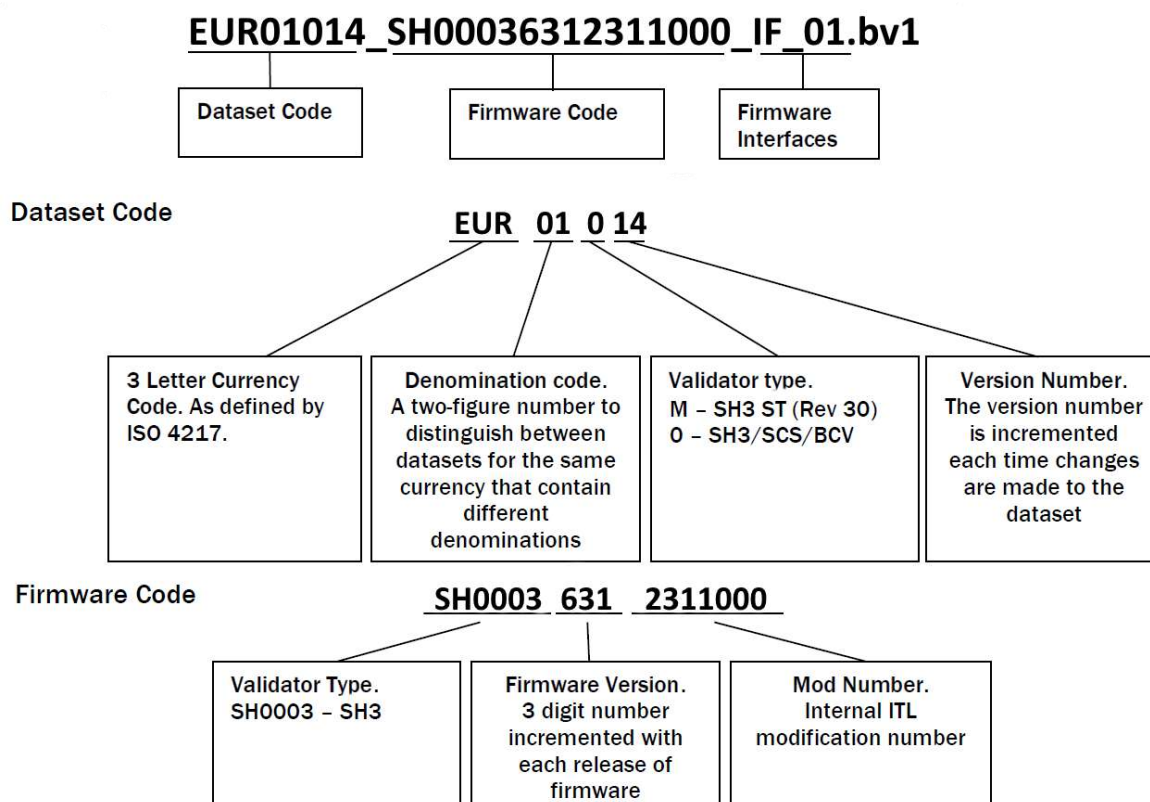

User Manual SMART Hopper

[<< Back to Contents](#)

11.8 Energy Profiles

11.8.1 Power up

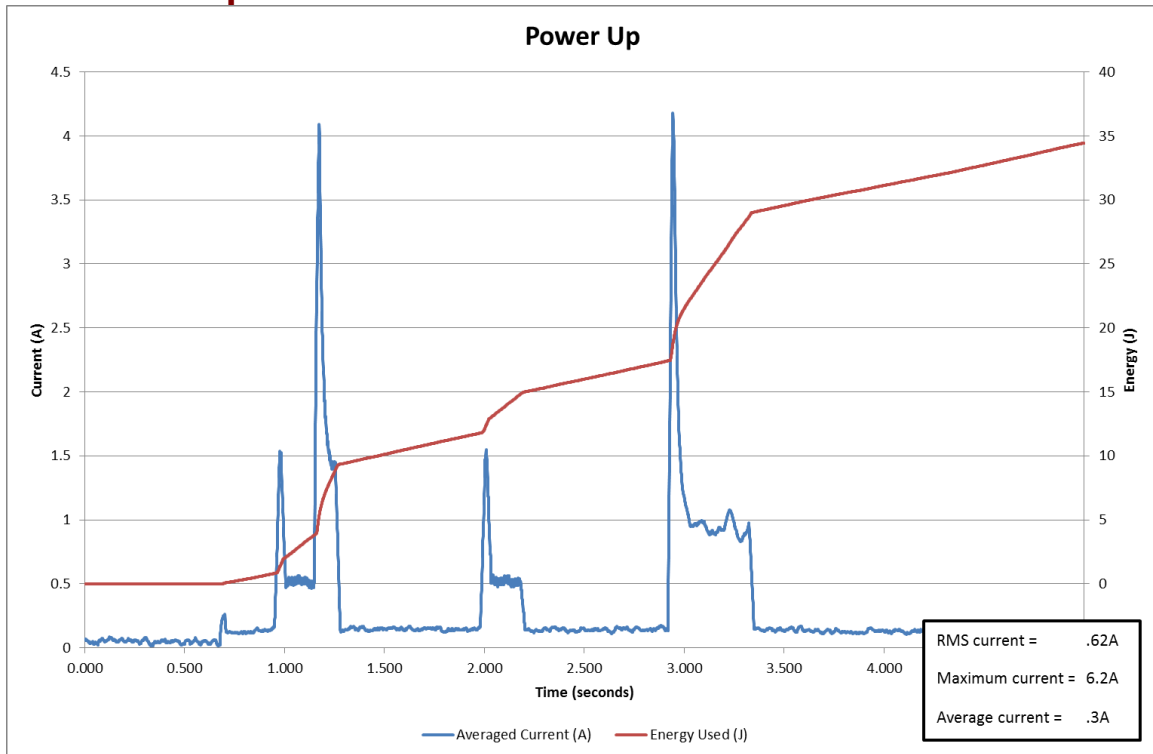

11.8.2 Idle

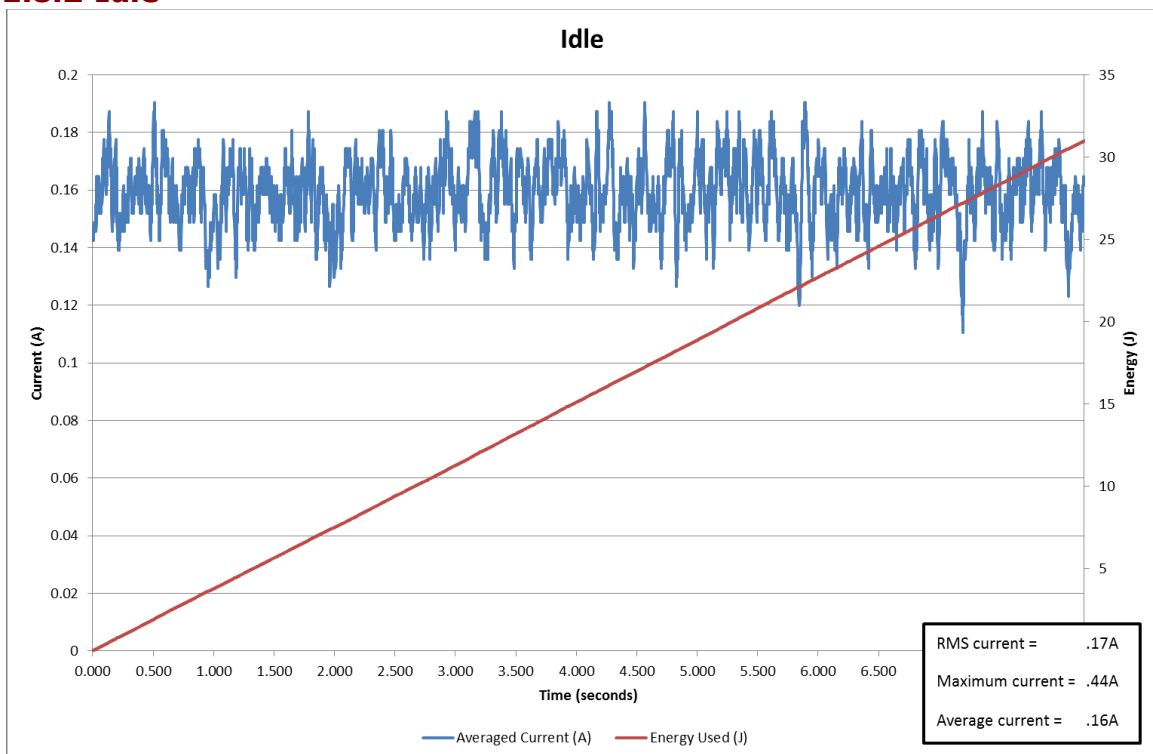

User Manual SMART Hopper

[<< Back to Contents](#)

11.8.3 Pay out

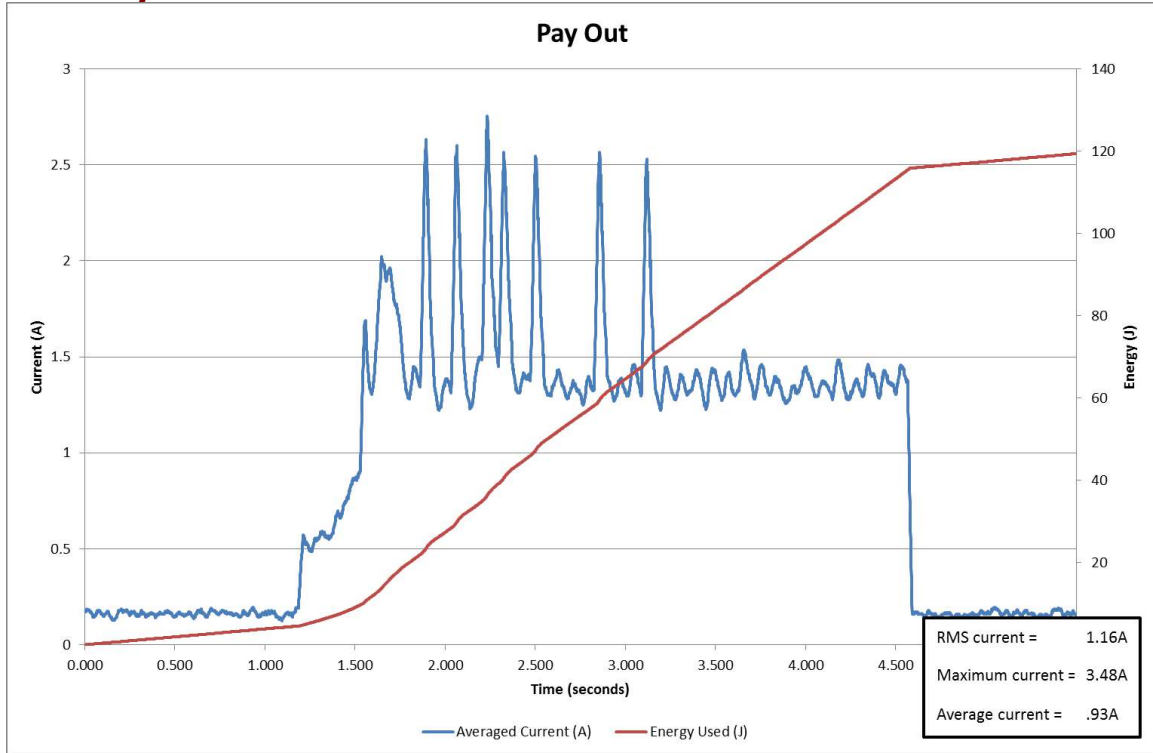

11.8.4 Empty

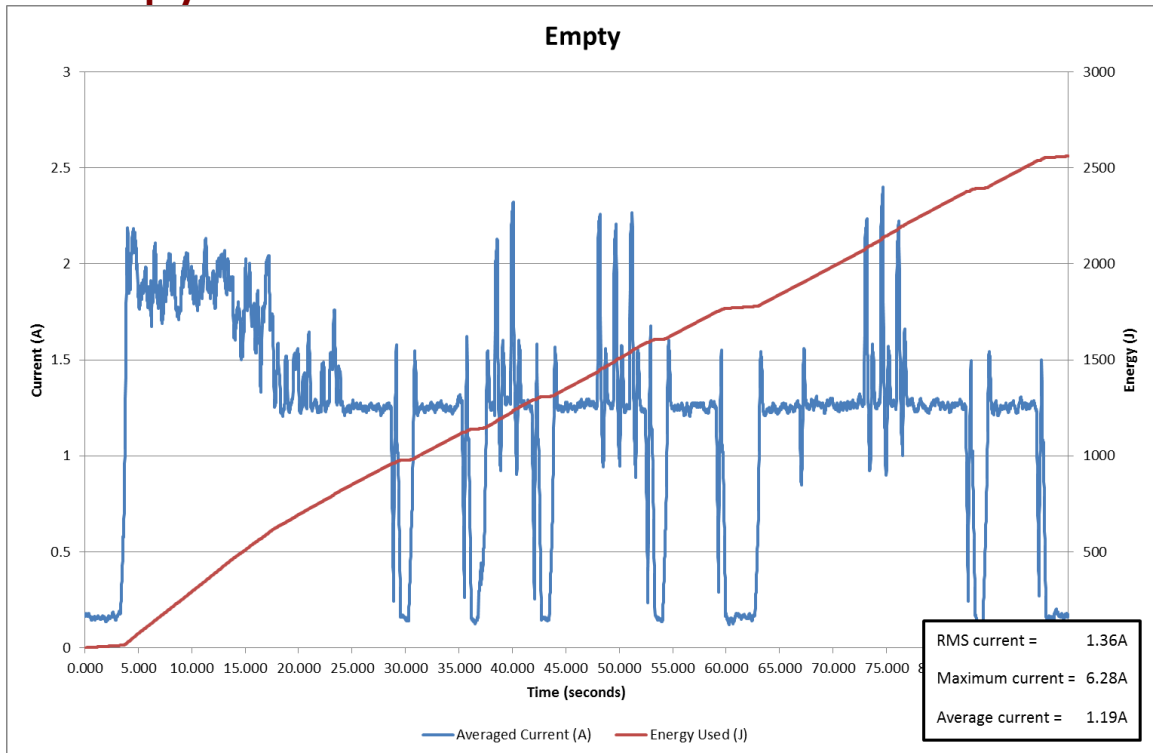

User Manual SMART Hopper

[<< Back to Contents](#)

11.8.5 Coin Jam

